

2J7183Bc
(Alpha Micro Part No. AMC2J7183Bc)
4 x 5G NR MIMO screw mount antenna

Features

- **Cables 1 - 4: 5G NR**
 - 617 – 960MHz
 - 1427 – 2690MHz
 - 3300 – 5000MHz
 - 5150 – 5925MHz
- Screw mount
- Heavy duty antenna
- High performance
- Ground plane independent
- Anti-rotation mounting
- Dimensions: Ø 96 x 130mm(h)
- Certificates: IP67, IP69, IK09
- Customizable cables and connectors



1. Antenna and Electrical Specifications

Cable 1

Parameters	5G NR Antenna			
Technologies	5G, 4G, 3G, 2G			
Standards	5G NR/4G LTE/FirstNet/CBRS/LPWA/CAT-X/Cat-Mx/CAT-NBx/NB-IoT/3G/2G			
Frequency (MHz)	617 - 960	1427 - 2690	3300 -5000	5150 - 5925
Band (MHz)	600, 700, 850, 900	1500, 1600, 1700, 1800, 1900, 2000, 2100, 2300, 2500, 2600	3300, 3500, 3600, 3700, 4500	5200, 5500, 5800
5G NR Bands	n5, n8, n12, n20, n28, n71, n81, n83	n1, n2, n3, n7, n25, n34, n38, n40, n41, n50, n51, n66, n70, n74, n75, n76, n80, n84, n86	n77, n78, n79	
4G LTE Bands	B5, B6, B8, B12, B13, B14, B17, B18, B19, B20, B26, B27, B28, B29, B44, B67, B68, B71, B85	B1, B2, B3, B4, B7, B9, B10, B11, B21, B23, B24, B25, B30, B32, B33, B34, B35, B36, B37, B38, B39, B40, B41, B45, B50, B51, B65, B66, B69, B70, B74, B75, B76	B22, B42, 43, B48, B49, B52	B46, B47, B252, B255
3G CELL Bands	B5, B6, B8, B12, B13, B14, B19, B20, B26	B1, B2, B3, B4, B7, B9, B10, B11, B21, B25, B32, B33, B34, B35, B36, B37, B38, B39, B40	B22	
2G CELL Bands	710, 750, 810T, 850, 900P, 900E, 900R	1800DCS, 1900PCS		
CDMA CELL Bands	BC0, BC2, BC3, BC7, BC9, BC10, BC12, BC18, BC19	BC1, BC4, BC6, BC8, BC13, BC14, BC15, BC16, BC20, BC21		
Return Loss (dB)	~-5.5	~-12.2	~-15.2	~-14.2
VSWR	~3.7:1	~2.0:1	~1.5:1	~1.6:1
Efficiency (%)	~31.0	~41.6	~41.6	~36.9
Peak Gain (dBi)	~1.3	~3.4	~4.7	~4.0
Average Gain (dBi)	~-5.1	~-3.9	~-3.8	~-4.4
Impedance (Ohms)	50			
Polarisation	Linear			
Radiation Pattern	Omni-directional			
Max I/P Power (W)	35			
Connector Type	SMA male standard (other connectors available)			
Cable Length	3 meters standard (other lengths available)			
Cable Type	LMR195 (other cables available)			

Cable 2

Parameters	5G NR Antenna			
Technologies	5G, 4G, 3G, 2G			
Standards	5G NR/4G LTE/FirstNet/CBRS/LPWA/CAT-X/Cat-Mx/CAT-NBx/NB-IoT/3G/2G			
Frequency (MHz)	617 - 960	1427 - 2690	3300 -5000	5150 - 5925
Band (MHz)	600, 700, 850, 900	1500, 1600, 1700, 1800, 1900, 2000, 2100, 2300, 2500, 2600	3300, 3500, 3600, 3700, 4500	5200, 5500, 5800
5G NR Bands	n5, n8, n12, n20, n28, n71, n81, n83	n1, n2, n3, n7, n25, n34, n38, n40, n41, n50, n51, n66, n70, n74, n75, n76, n80, n84, n86	n77, n78, n79	
4G LTE Bands	B5, B6, B8, B12, B13, B14, B17, B18, B19, B20, B26, B27, B28, B29, B44, B67, B68, B71, B85	B1, B2, B3, B4, B7, B9, B10, B11, B21, B23, B24, B25, B30, B32, B33, B34, B35, B36, B37, B38, B39, B40, B41, B45, B50, B51, B65, B66, B69, B70, B74, B75, B76	B22, B42, 43, B48, B49, B52	B46, B47, B252, B255
3G CELL Bands	B5, B6, B8, B12, B13, B14, B19, B20, B26	B1, B2, B3, B4, B7, B9, B10, B11, B21, B25, B32, B33, B34, B35, B36, B37, B38, B39, B40	B22	
2G CELL Bands	710, 750, 810T, 850, 900P, 900E, 900R	1800DCS, 1900PCS		
CDMA CELL Bands	BC0, BC2, BC3, BC7, BC9, BC10, BC12, BC18, BC19	BC1, BC4, BC6, BC8, BC13, BC14, BC15, BC16, BC20, BC21		
Return Loss (dB)	~-5.6	~-12.7	~-15.3	~-16.0
VSWR	~3.7:1	~1.9:1	~1.5:1	~1.5:1
Efficiency (%)	~31.2	~41.4	~42.4	~33.1
Peak Gain (dBi)	~1.2	~3.6	~4.6	~3.2
Average Gain (dBi)	~-5.1	~-3.9	~-3.8	~-4.8
Impedance (Ohms)	50			
Polarisation	Linear			
Radiation Pattern	Omni-directional			
Max I/P Power (W)	35			
Connector Type	SMA male standard (other connectors available)			
Cable Length	3 meters standard (other lengths available)			
Cable Type	LMR195 (other cables available)			

Cable 3

Parameters	5G NR Antenna			
Technologies	5G, 4G, 3G, 2G			
Standards	5G NR/4G LTE/FirstNet/CBRS/LPWA/CAT-X/Cat-Mx/CAT-NBx/NB-IoT/3G/2G			
Frequency (MHz)	617 - 960	1427 - 2690	3300 -5000	5150 - 5925
Band (MHz)	600, 700, 850, 900	1500, 1600, 1700, 1800, 1900, 2000, 2100, 2300, 2500, 2600	3300, 3500, 3600, 3700, 4500	5200, 5500, 5800
5G NR Bands	n5, n8, n12, n20, n28, n71, n81, n83	n1, n2, n3, n7, n25, n34, n38, n40, n41, n50, n51, n66, n70, n74, n75, n76, n80, n84, n86	n77, n78, n79	
4G LTE Bands	B5, B6, B8, B12, B13, B14, B17, B18, B19, B20, B26, B27, B28, B29, B44, B67, B68, B71, B85	B1, B2, B3, B4, B7, B9, B10, B11, B21, B23, B24, B25, B30, B32, B33, B34, B35, B36, B37, B38, B39, B40, B41, B45, B50, B51, B65, B66, B69, B70, B74, B75, B76	B22, B42, 43, B48, B49, B52	B46, B47, B252, B255
3G CELL Bands	B5, B6, B8, B12, B13, B14, B19, B20, B26	B1, B2, B3, B4, B7, B9, B10, B11, B21, B25, B32, B33, B34, B35, B36, B37, B38, B39, B40	B22	
2G CELL Bands	710, 750, 810T, 850, 900P, 900E, 900R	1800DCS, 1900PCS		
CDMA CELL Bands	BC0, BC2, BC3, BC7, BC9, BC10, BC12, BC18, BC19	BC1, BC4, BC6, BC8, BC13, BC14, BC15, BC16, BC20, BC21		
Return Loss (dB)	~-5.4	~-12.9	~-16.7	~-12.4
VSWR	~3.7:1	~1.8:1	~1.4:1	~1.8:1
Efficiency (%)	~31.5	~41.6	~40.3	~38.5
Peak Gain (dBi)	~1.3	~3.8	~4.5	~4.6
Average Gain (dBi)	~-5.0	~-3.8	~-4.0	~-4.2
Impedance (Ohms)	50			
Polarisation	Linear			
Radiation Pattern	Omni-directional			
Max I/P Power (W)	35			
Connector Type	SMA male standard (other connectors available)			
Cable Length	3 meters standard (other lengths available)			
Cable Type	LMR195 (other cables available)			

Cable 4

Parameters	5G NR Antenna			
Technologies	5G, 4G, 3G, 2G			
Standards	5G NR/4G LTE/FirstNet/CBRS/LPWA/CAT-X/Cat-Mx/CAT-NBx/NB-IoT/3G/2G			
Frequency (MHz)	617 - 960	1427 - 2690	3300 -5000	5150 - 5925
Band (MHz)	600, 700, 850, 900	1500, 1600, 1700, 1800, 1900, 2000, 2100, 2300, 2500, 2600	3300, 3500, 3600, 3700, 4500	5200, 5500, 5800
5G NR Bands	n5, n8, n12, n20, n28, n71, n81, n83	n1, n2, n3, n7, n25, n34, n38, n40, n41, n50, n51, n66, n70, n74, n75, n76, n80, n84, n86	n77, n78, n79	
4G LTE Bands	B5, B6, B8, B12, B13, B14, B17, B18, B19, B20, B26, B27, B28, B29, B44, B67, B68, B71, B85	B1, B2, B3, B4, B7, B9, B10, B11, B21, B23, B24, B25, B30, B32, B33, B34, B35, B36, B37, B38, B39, B40, B41, B45, B50, B51, B65, B66, B69, B70, B74, B75, B76	B22, B42, 43, B48, B49, B52	B46, B47, B252, B255
3G CELL Bands	B5, B6, B8, B12, B13, B14, B19, B20, B26	B1, B2, B3, B4, B7, B9, B10, B11, B21, B25, B32, B33, B34, B35, B36, B37, B38, B39, B40	B22	
2G CELL Bands	710, 750, 810T, 850, 900P, 900E, 900R	1800DCS, 1900PCS		
CDMA CELL Bands	BC0, BC2, BC3, BC7, BC9, BC10, BC12, BC18, BC19	BC1, BC4, BC6, BC8, BC13, BC14, BC15, BC16, BC20, BC21		
Return Loss (dB)	~-5.7	~-12.8	~-16.8	~-15.4
VSWR	~3.5:1	~1.8:1	~1.5:1	~1.5:1
Efficiency (%)	~31.2	~41.8	~42.5	~35.0
Peak Gain (dBi)	~1.6	~3.4	~4.6	~3.9
Average Gain (dBi)	~-5.1	~-3.9	~-3.8	~-4.6
Impedance (Ohms)	50			
Polarisation	Linear			
Radiation Pattern	Omni-directional			
Max I/P Power (W)	35			
Connector Type	SMA male standard (other connectors available)			
Cable Length	3 meters standard (other lengths available)			
Cable Type	LMR195 (other cables available)			

Measurement Conditions:

- Mounted on 30 x 30cm metal plate
- 2 meters of LMR195 cable
- Measured in certified CTIA 3D Anechoic chamber

. **Mechanical and Environmental Specifications**

Mounting Type	Screw mount
Dimensions (mm)	Ø 96 x H 130
Max. Tighten Torque (Nm)	15
Radome	ASA
Radome Color	Black or white
Antenna Base	Aluminium alloy
Operating Temperature (°C)	-40 to +85
Storage Temperature (°C)	-40 to +85
Substance Compliance	RoHS
Certificates	IP67, IP69, IK09

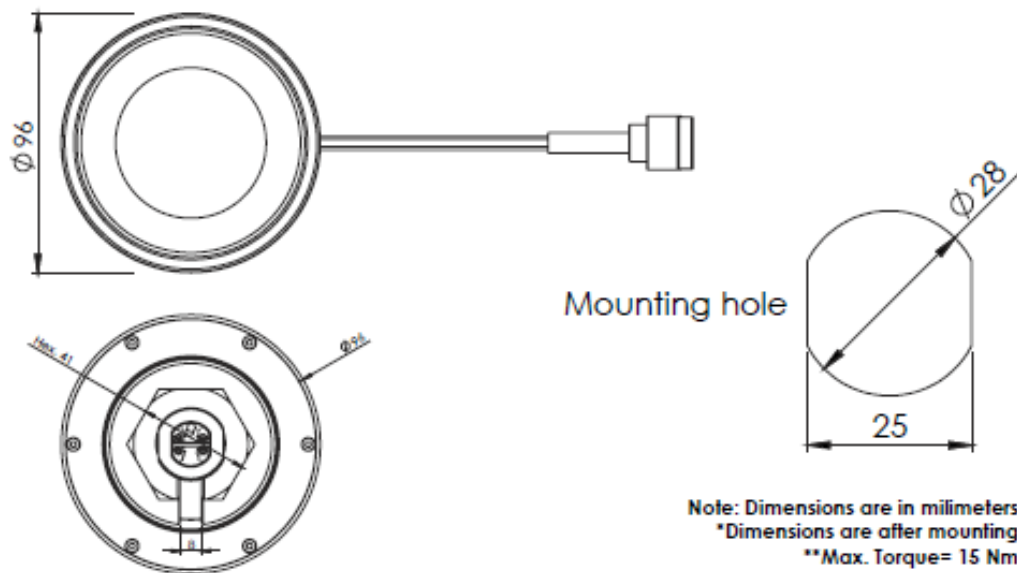
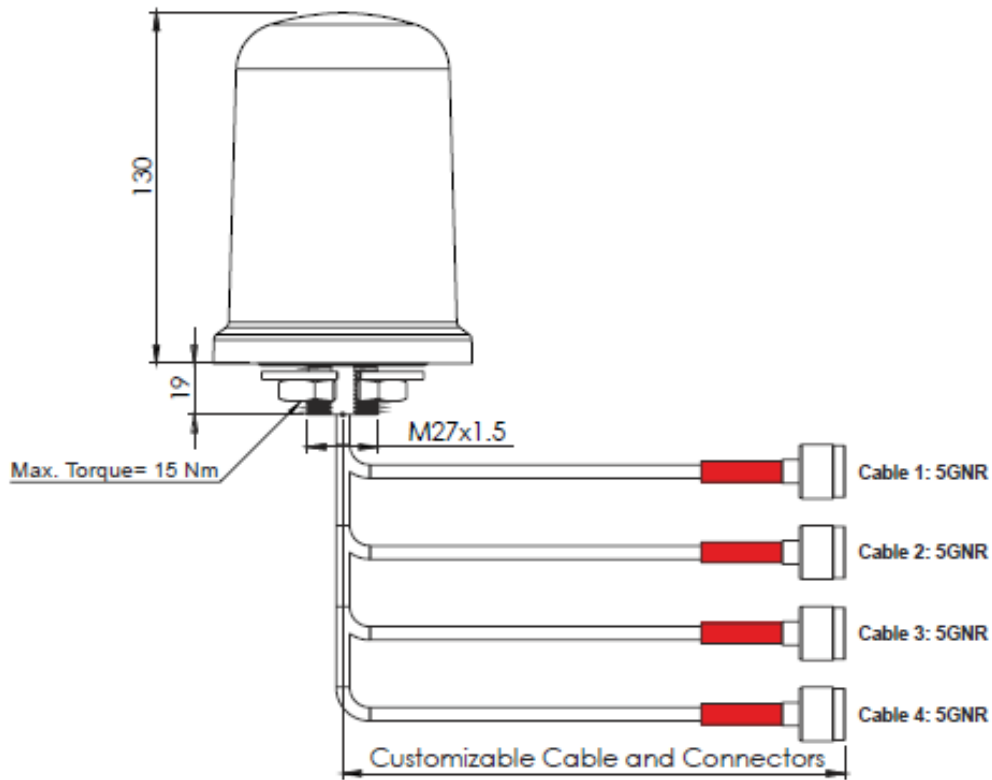

3. Antenna Parameters

Cable 1: 5GNR

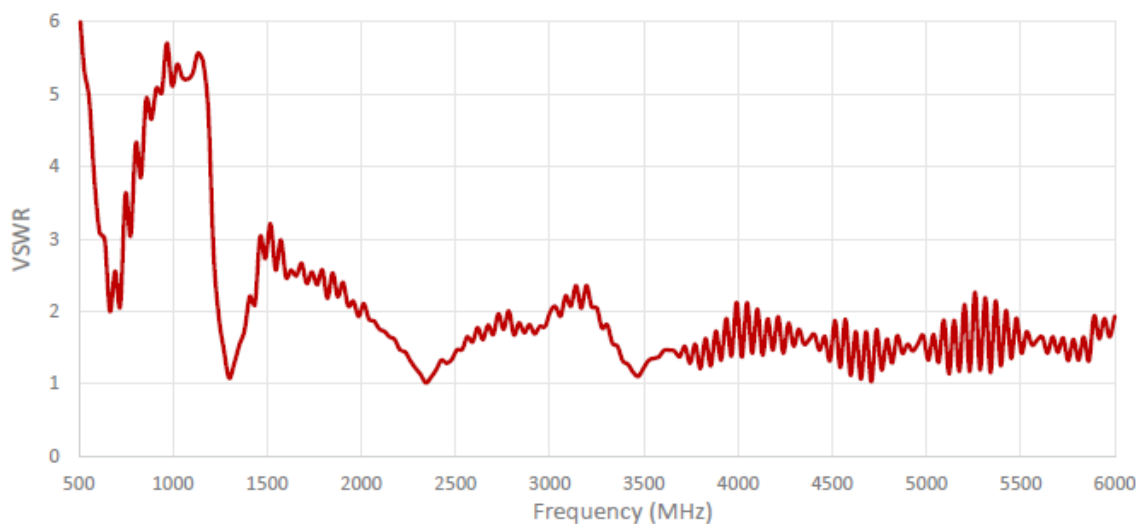
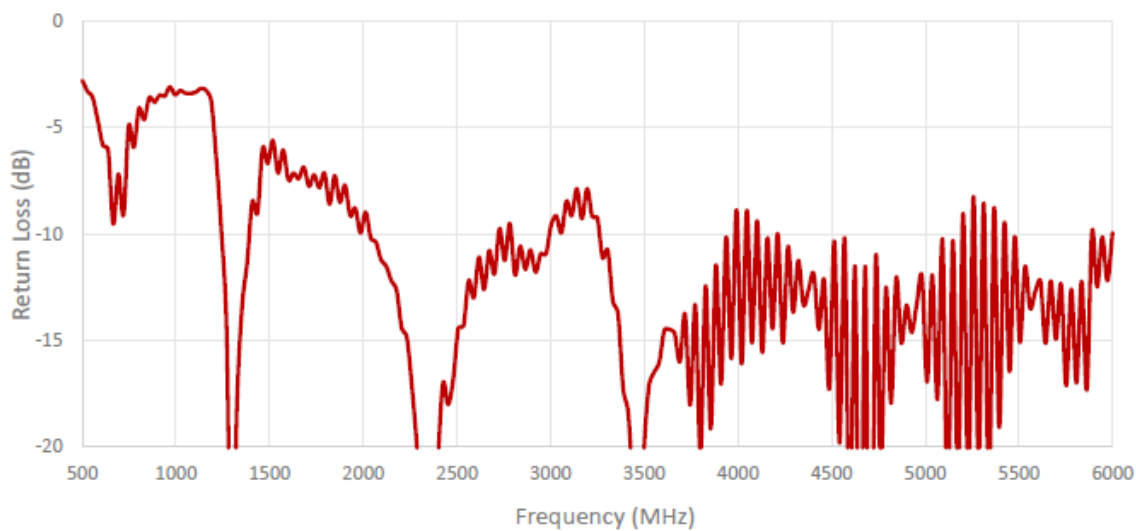

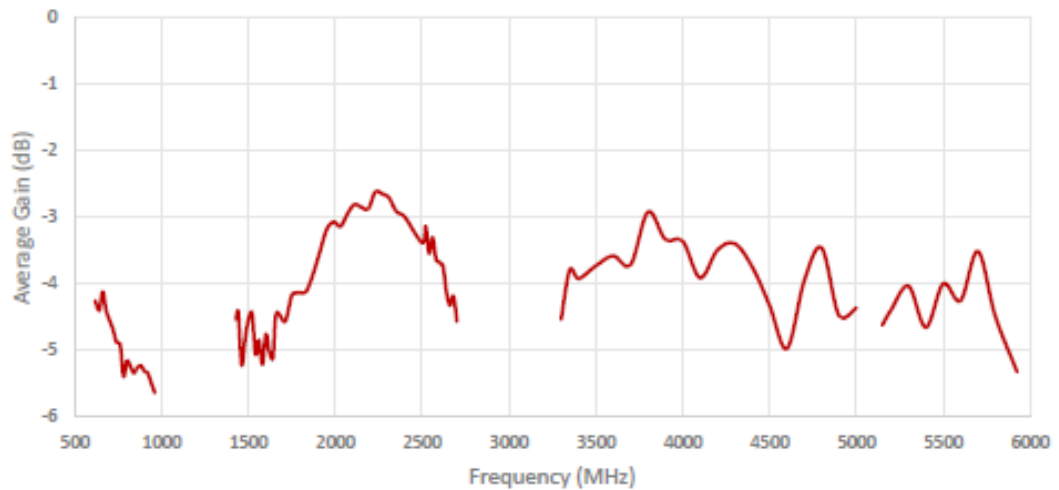
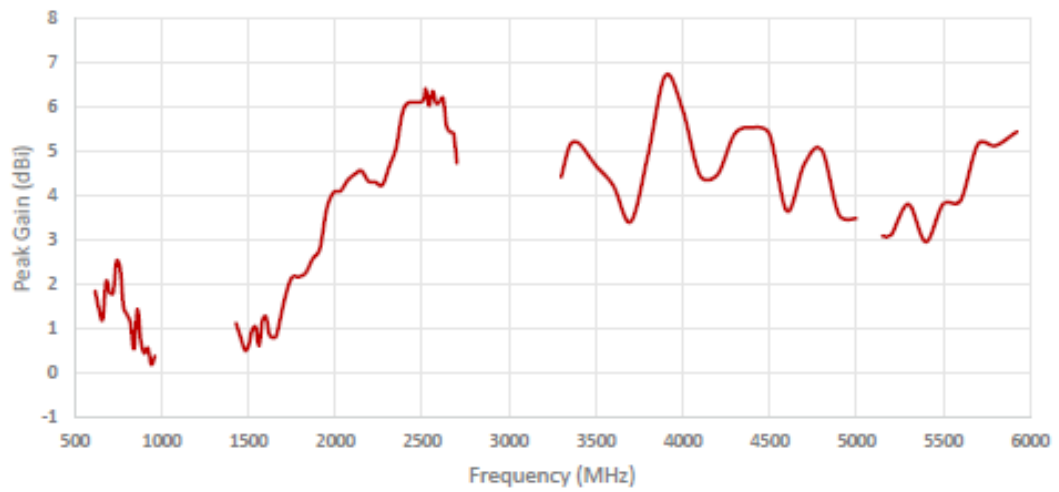
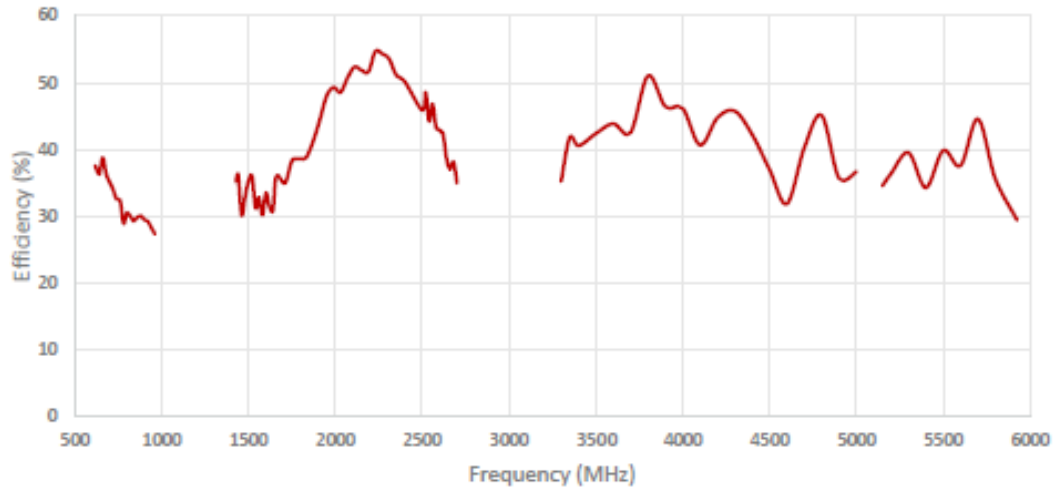

Cable 2: 5GNR

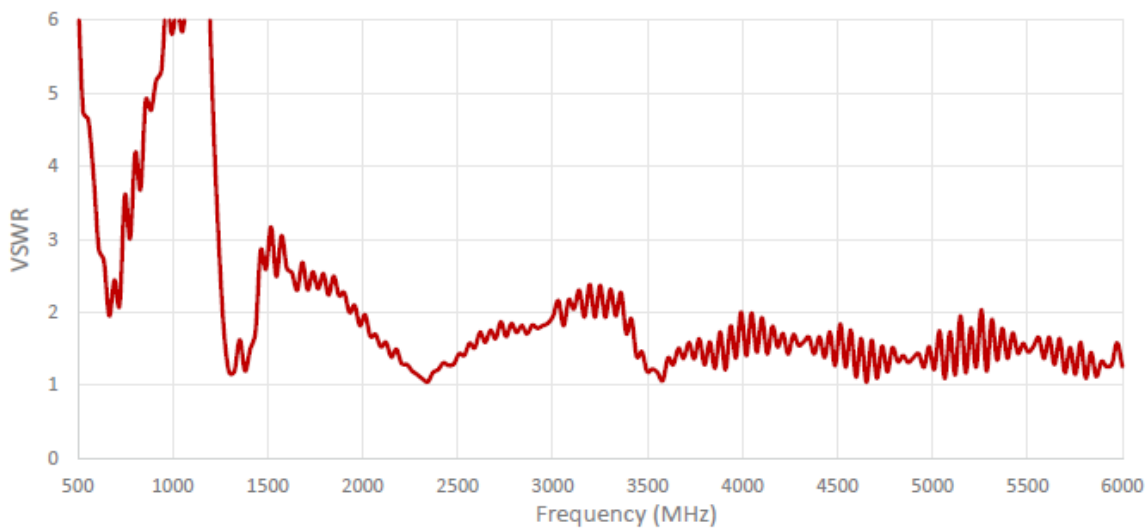
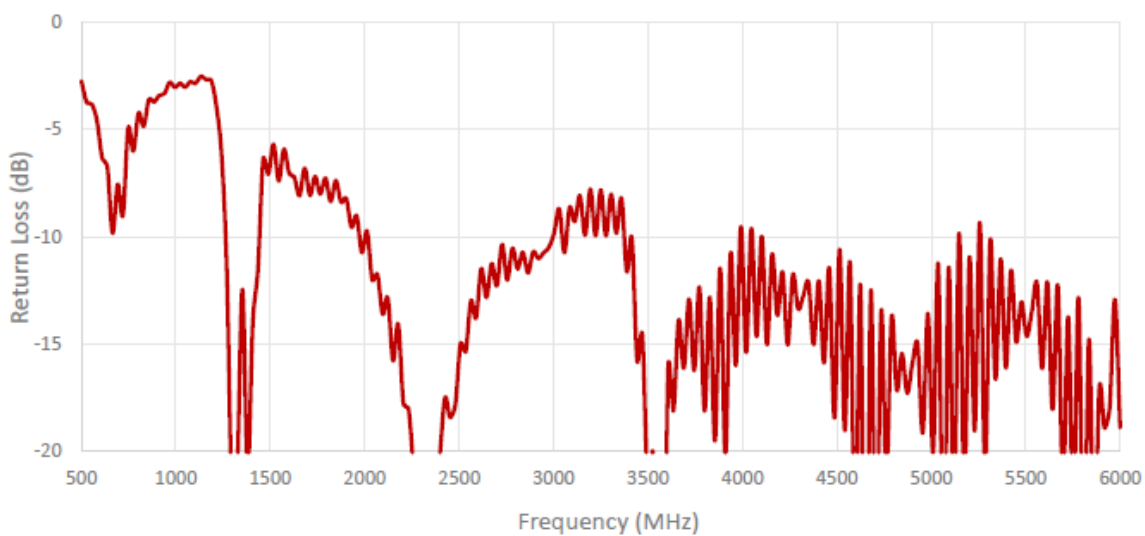

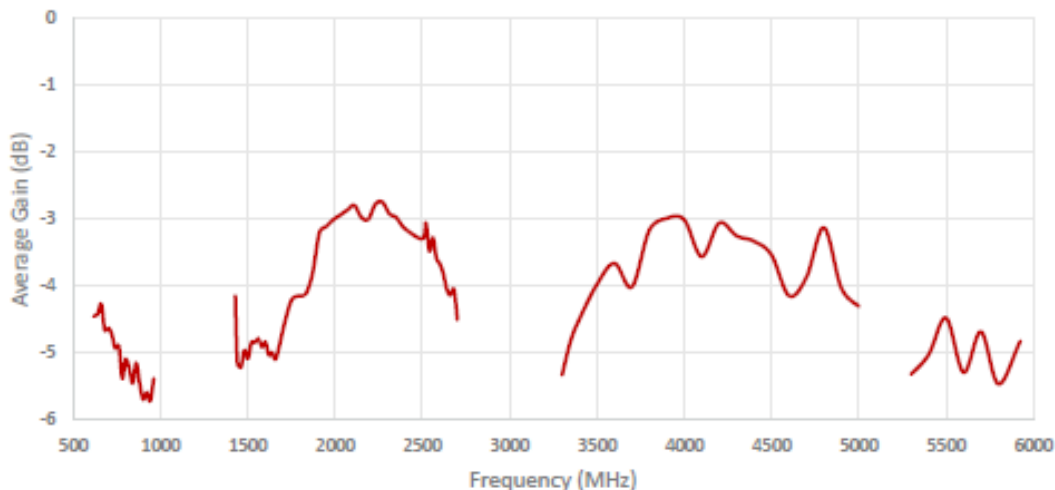
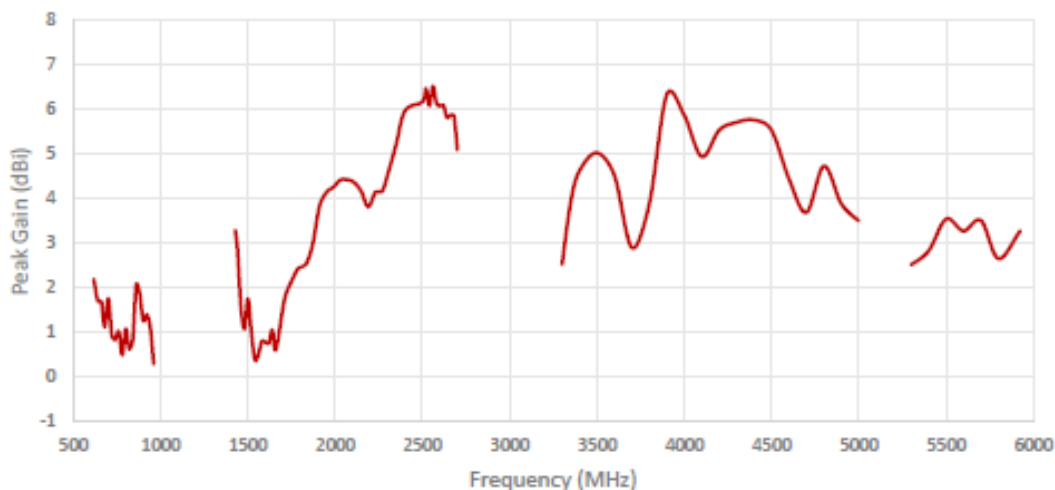
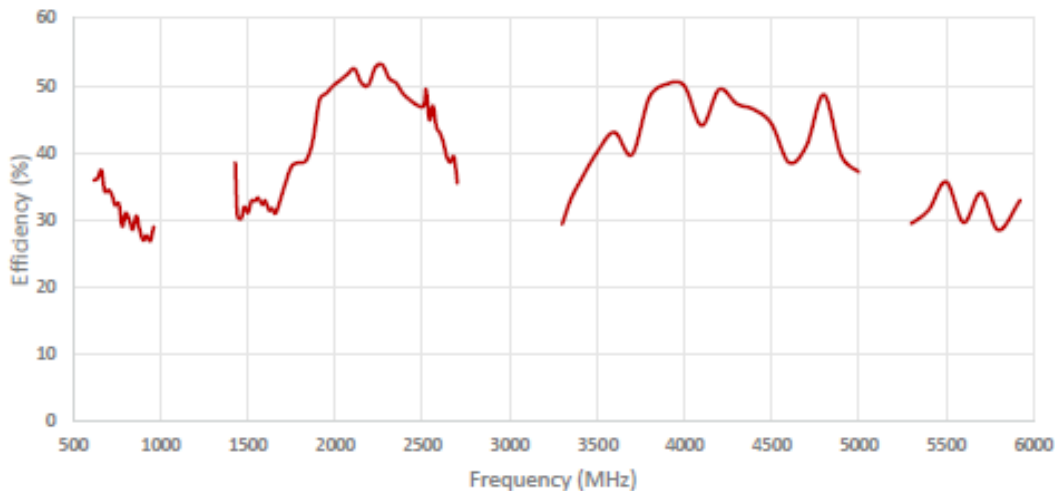

Cable 3: 5GNR

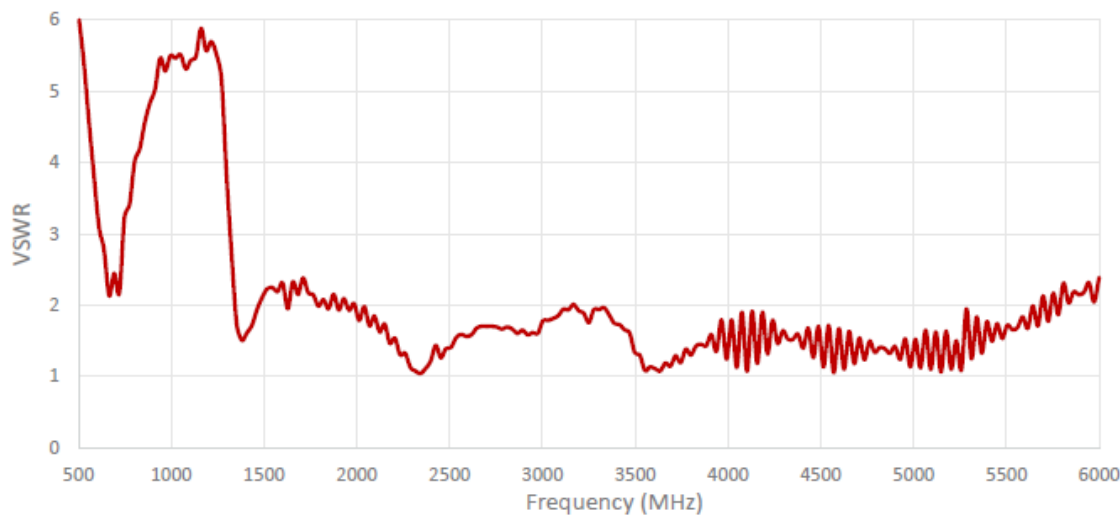
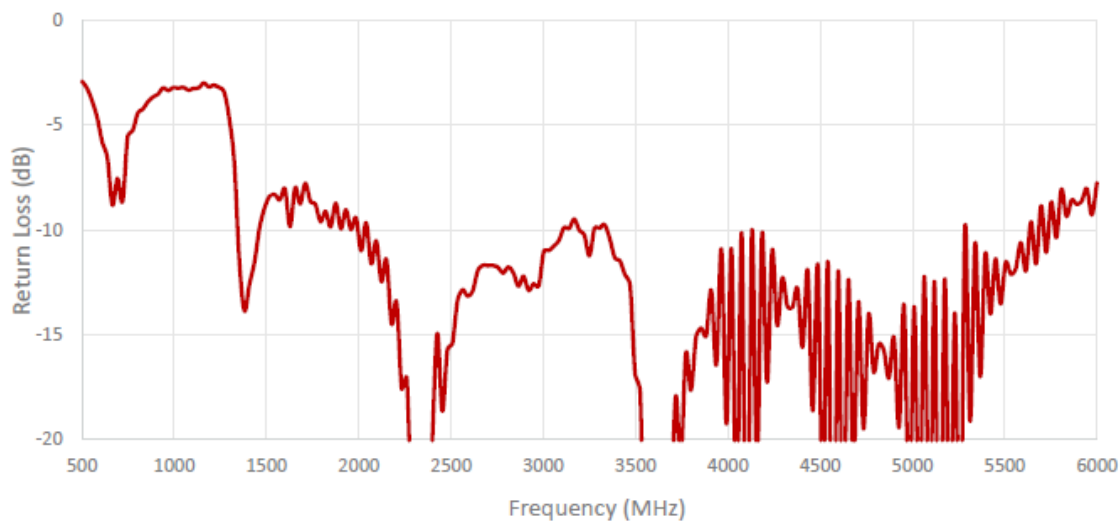

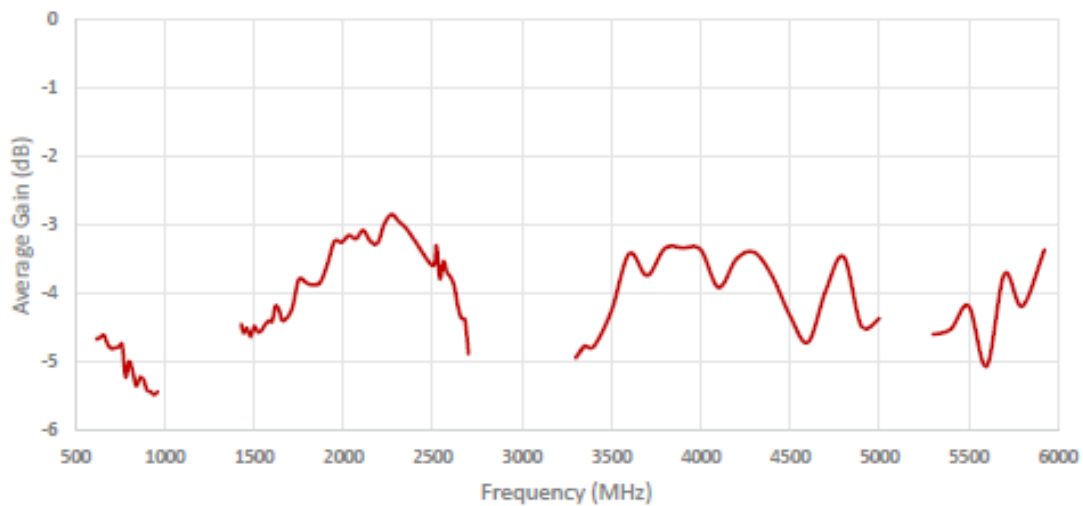
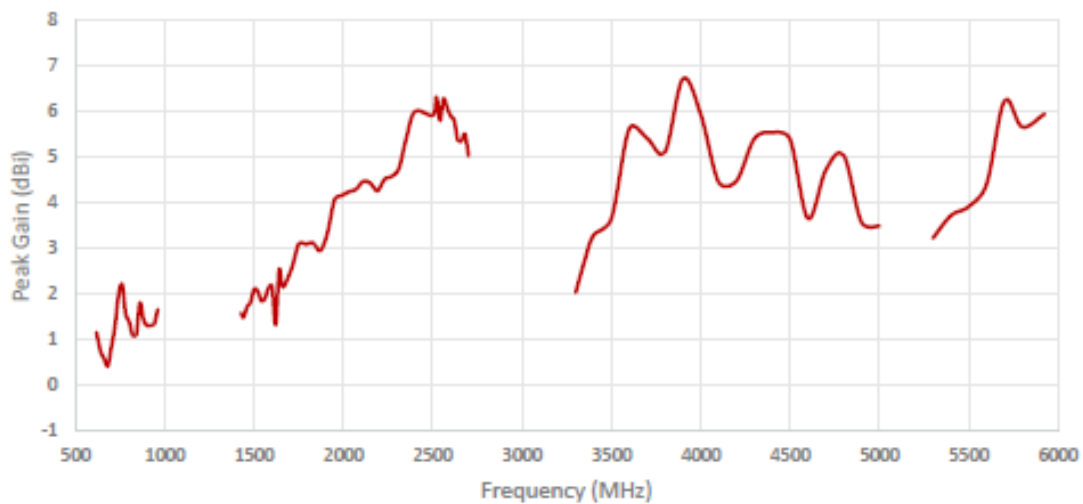
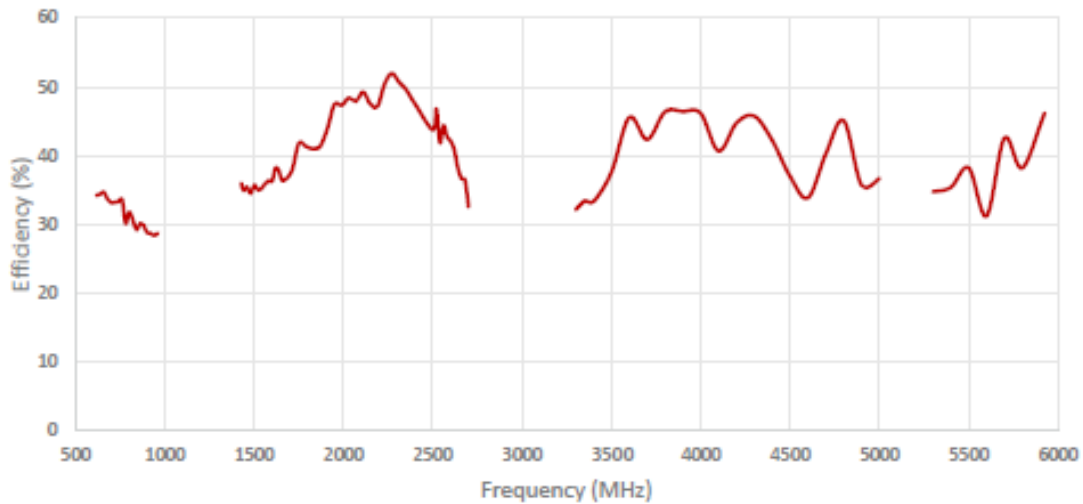

Cable 4: 5GNR

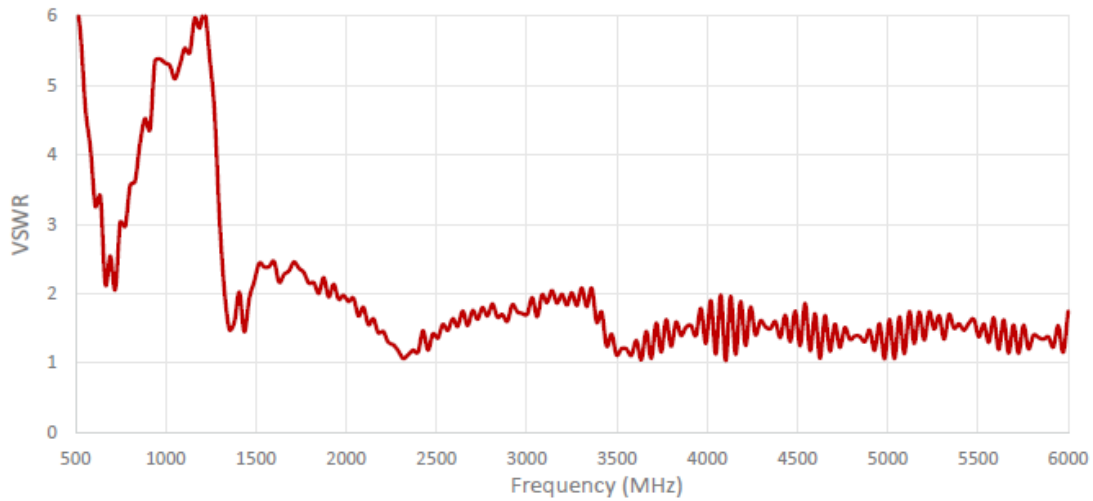
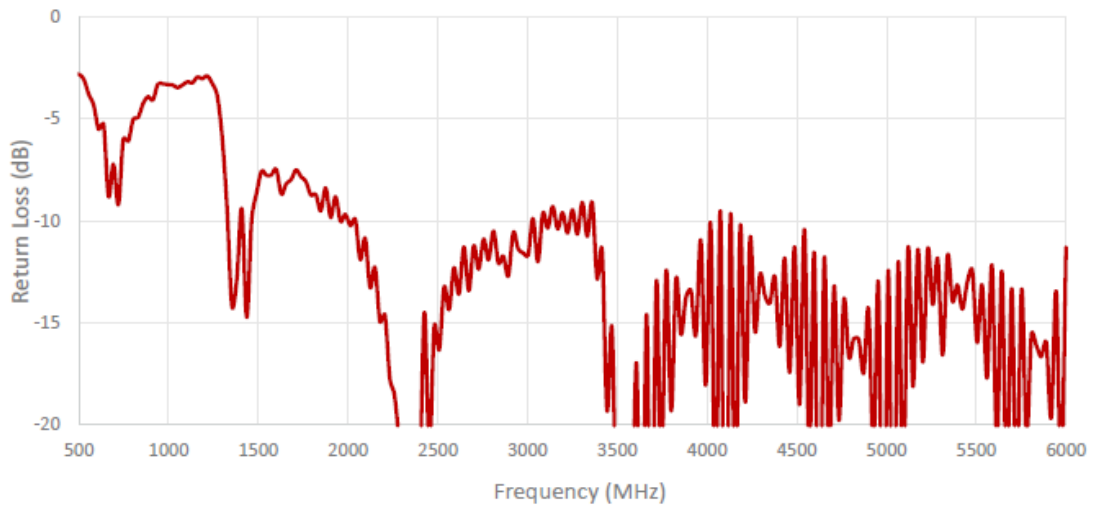

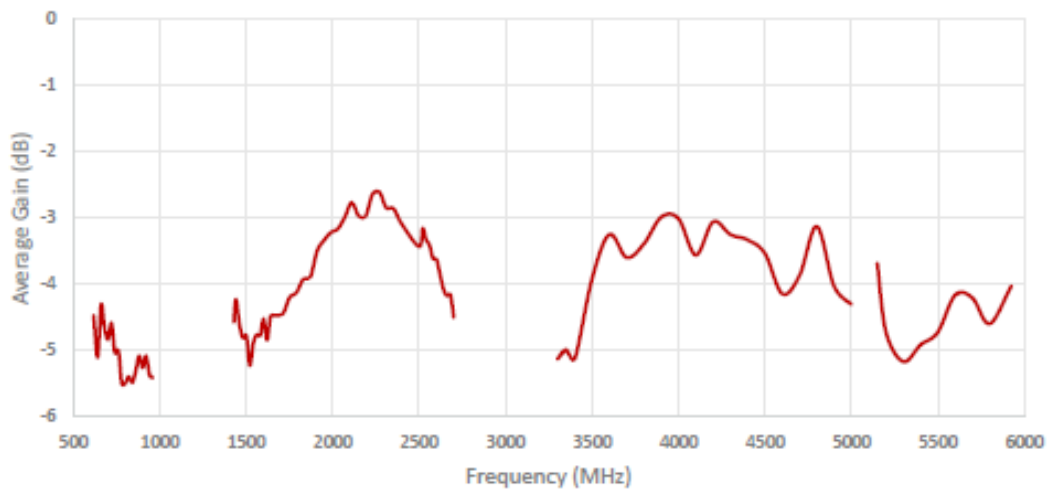
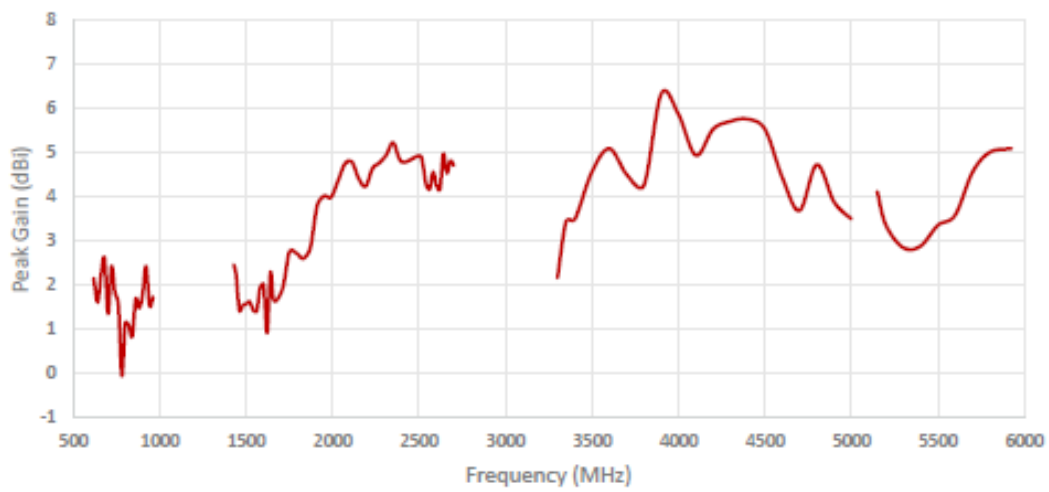
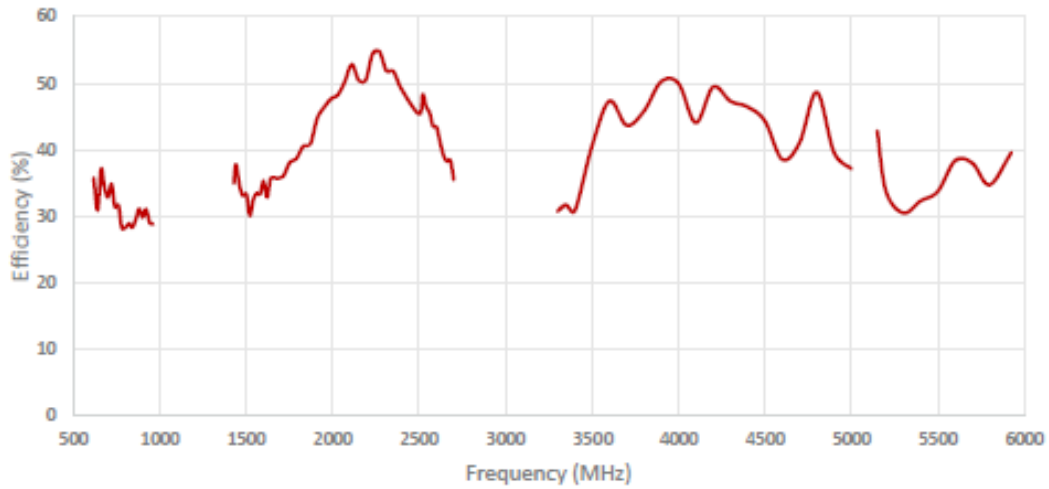

ISOLATION FOR CABLES 1 AND 2

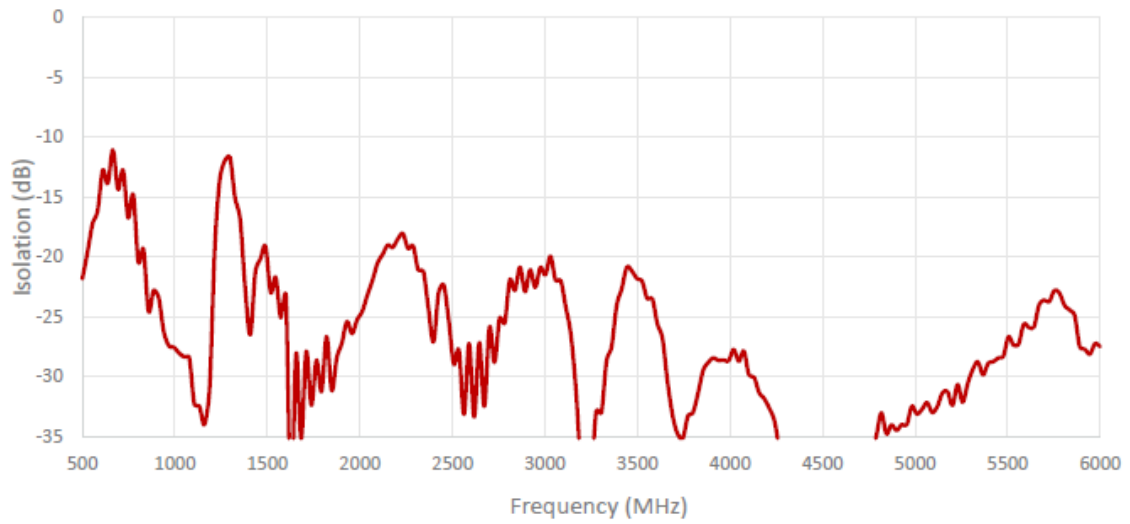

ISOLATION FOR CABLES 1 AND 3

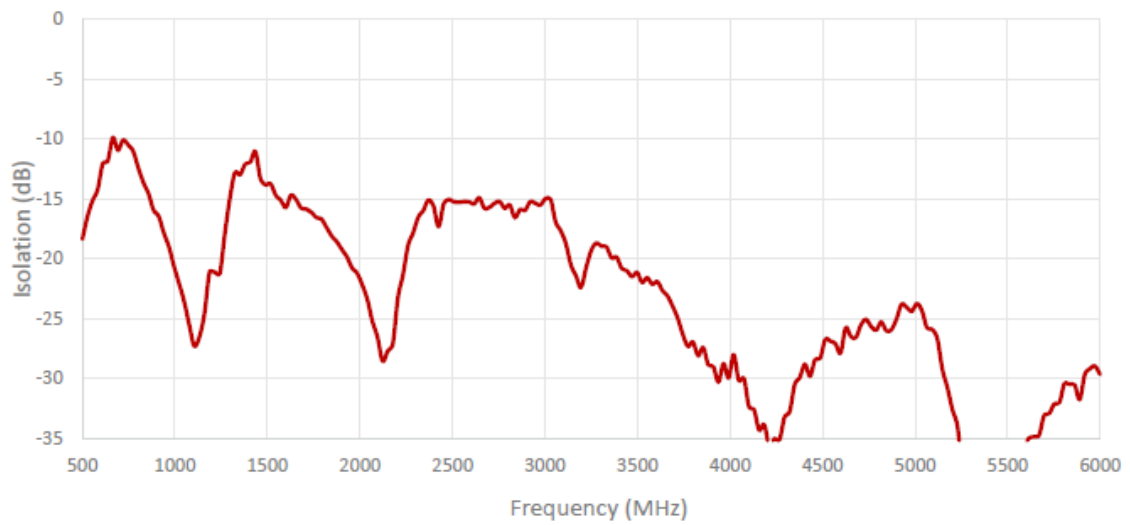

ISOLATION FOR CABLES 1 AND 4

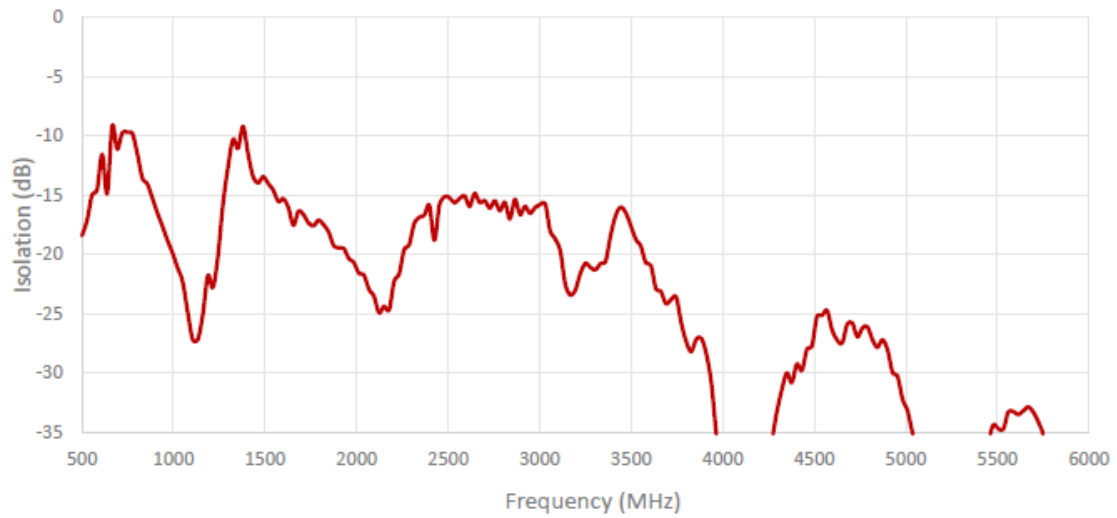

ISOLATION FOR CABLES 2 AND 3

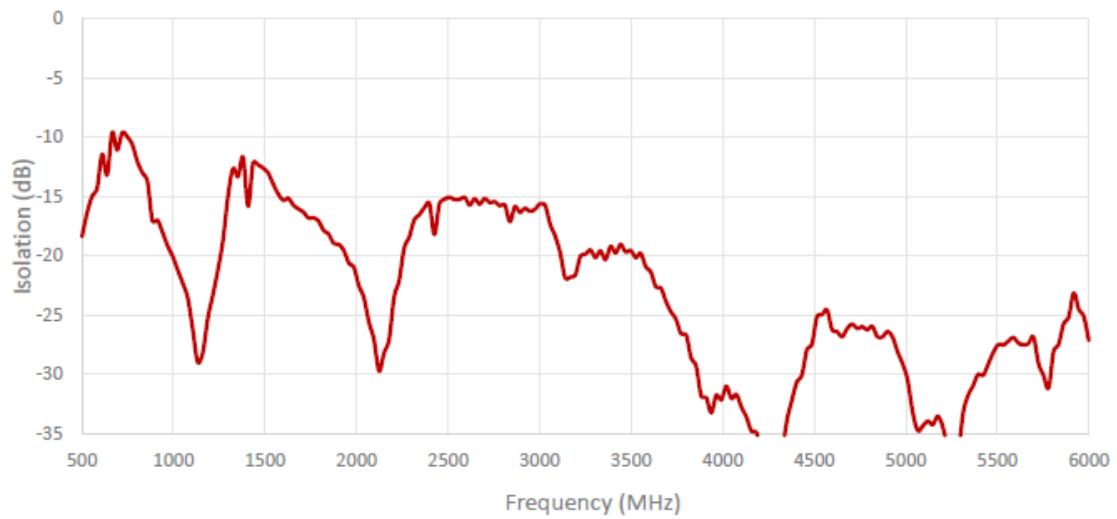

ISOLATION FOR CABLES 2 AND 4

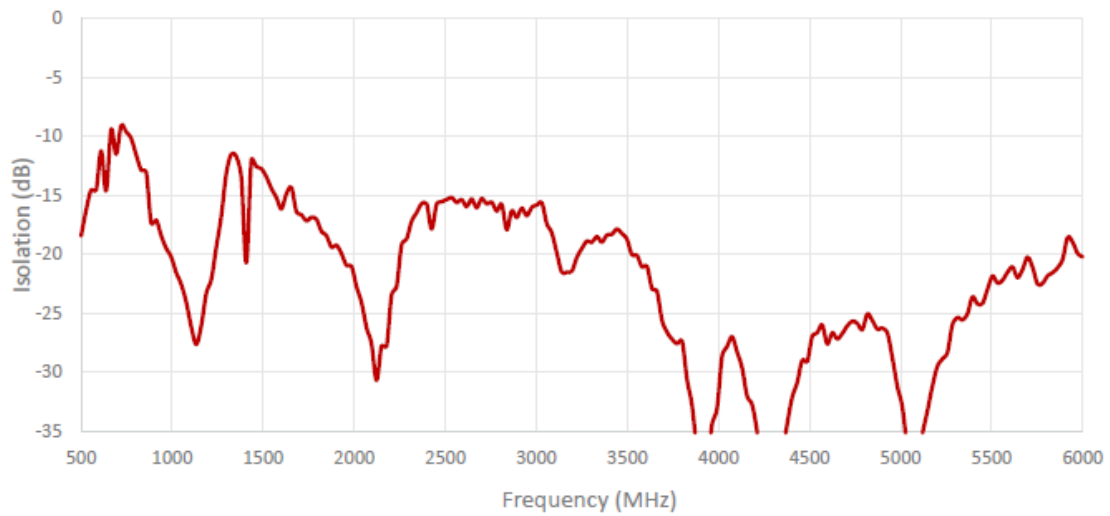

ISOLATION FOR CABLES 3 AND 4

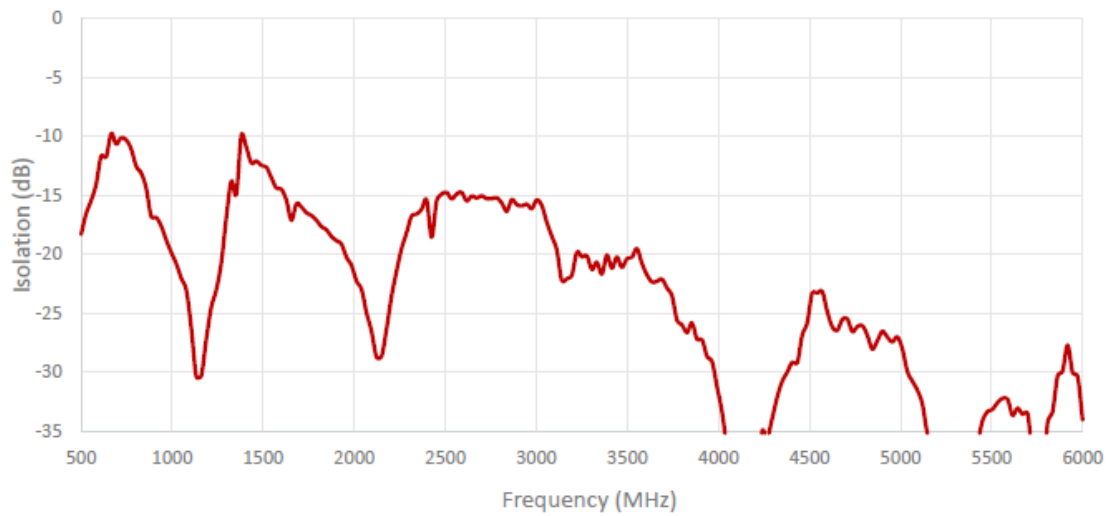

ENVELOPE CORRELATION COEFFICIENT FOR CABLES 1 AND 2

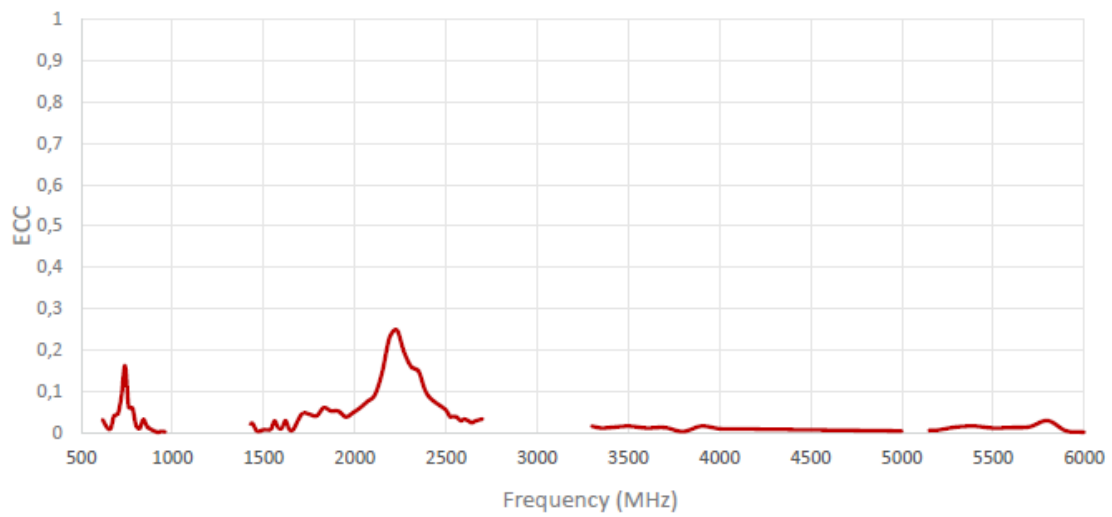

ENVELOPE CORRELATION COEFFICIENT FOR CABLES 1 AND 3

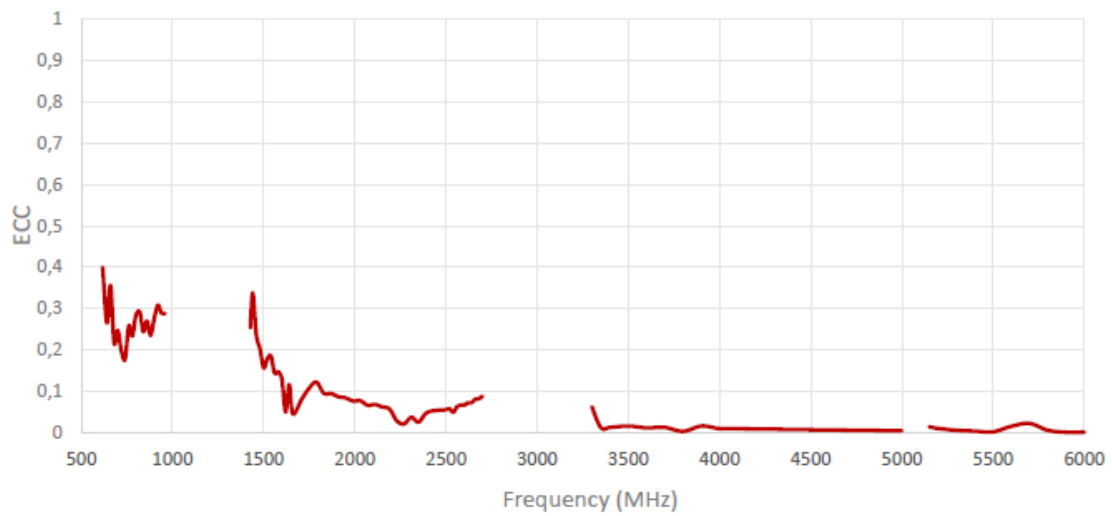

ENVELOPE CORRELATION COEFFICIENT FOR CABLES 1 AND 4

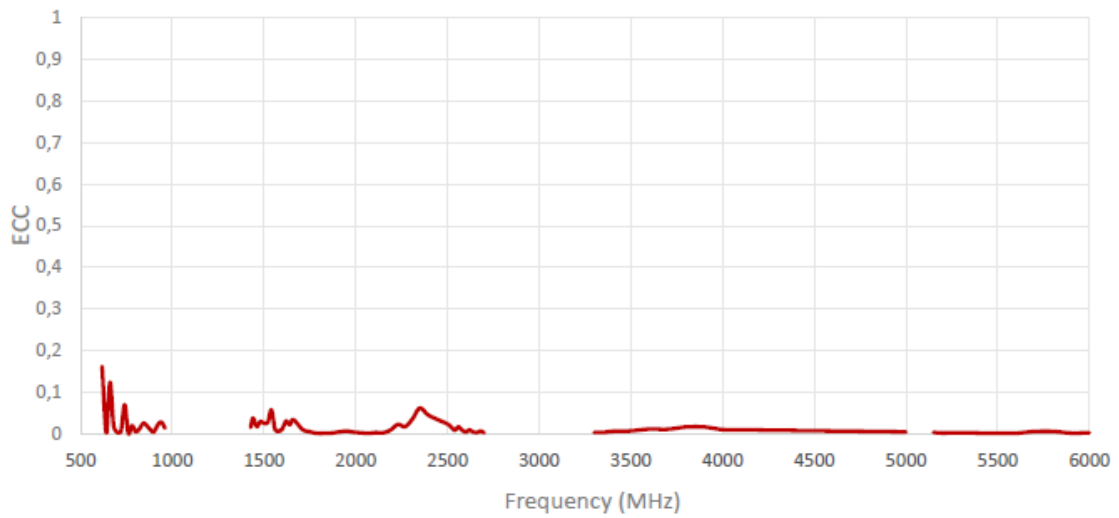

ENVELOPE CORRELATION COEFFICIENT FOR CABLES 2 AND 3

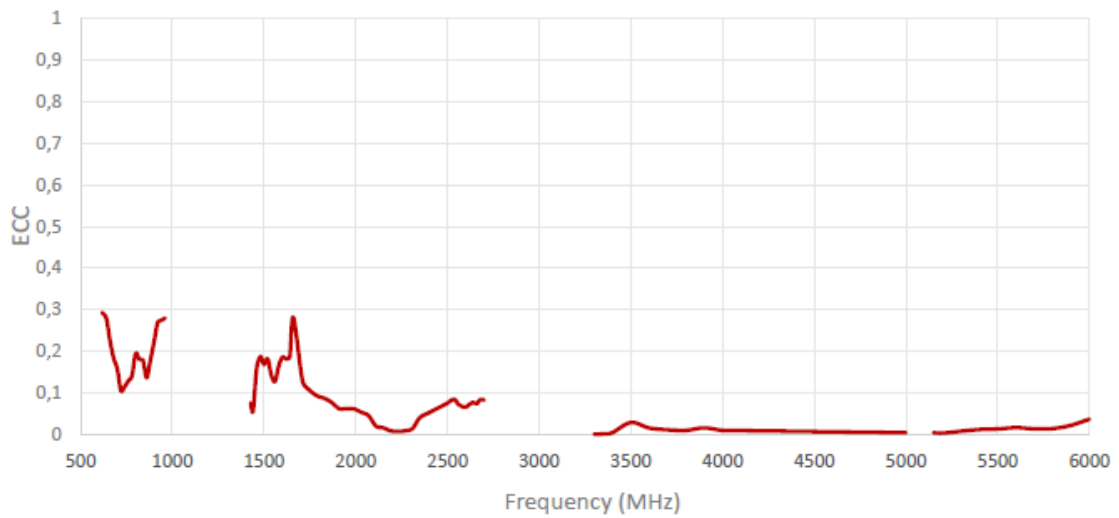

ENVELOPE CORRELATION COEFFICIENT FOR CABLES 2 AND 4

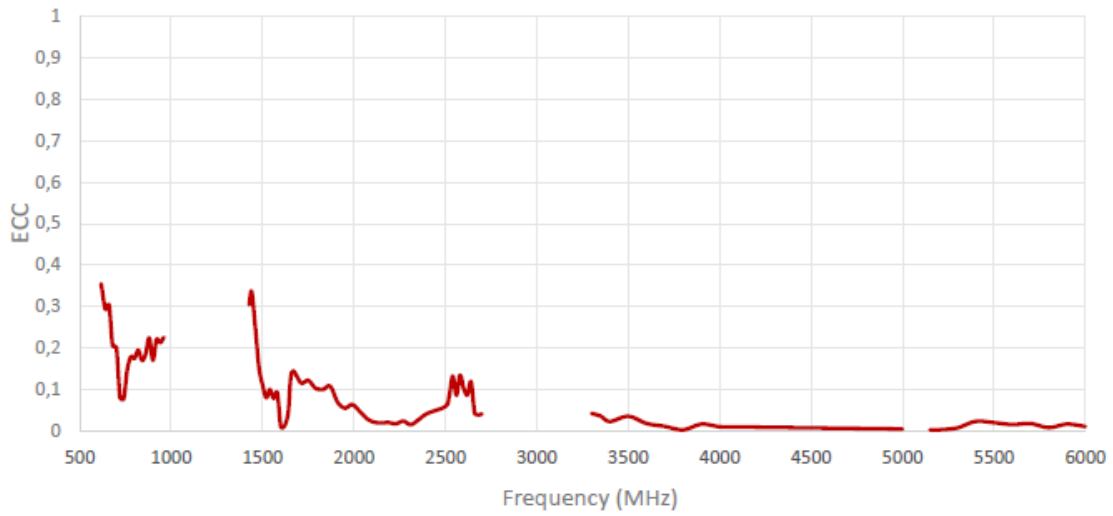

ENVELOPE CORRELATION COEFFICIENT FOR CABLES 3 AND 4

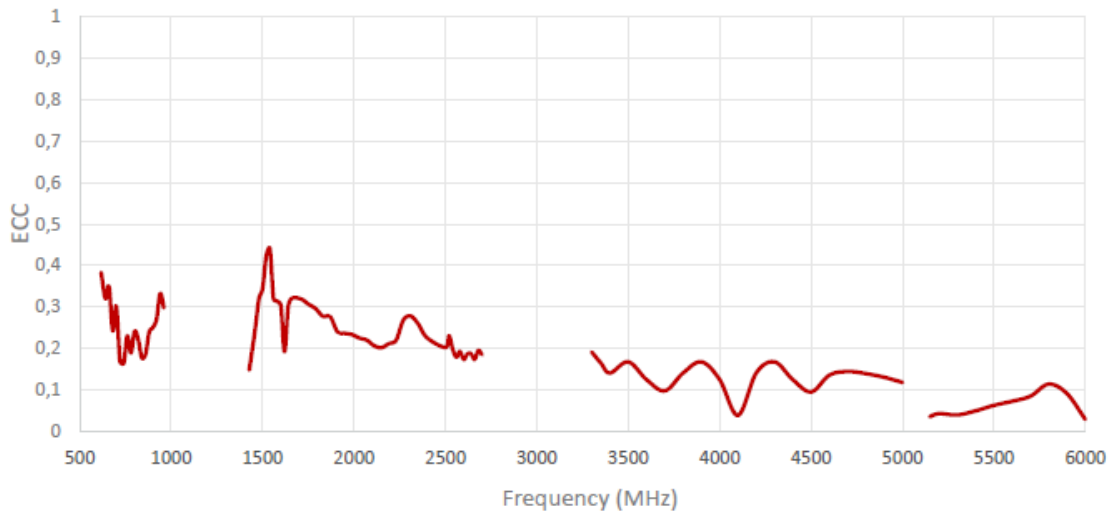



Radiation pattern reference

Cable 1: 5GNR

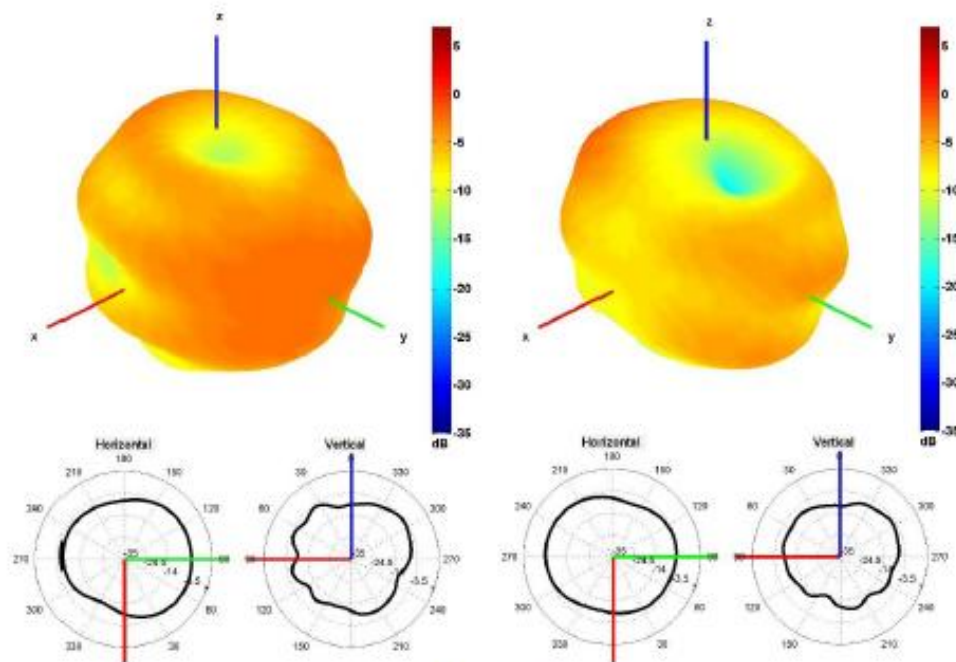

650 and 750 MHz Radiation pattern

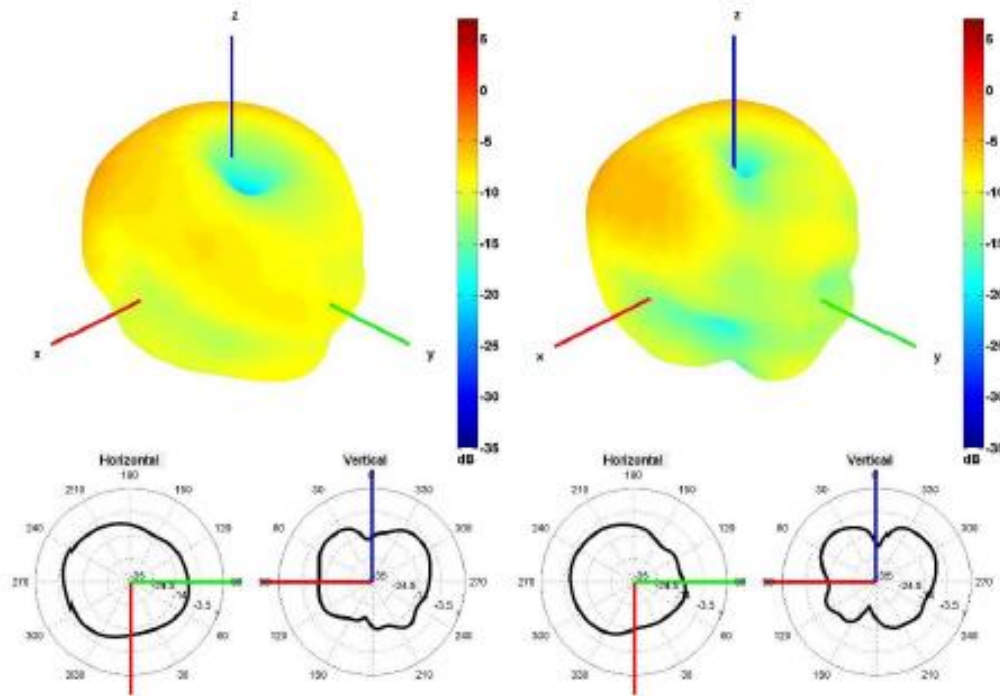

850 and 940 MHz Radiation pattern

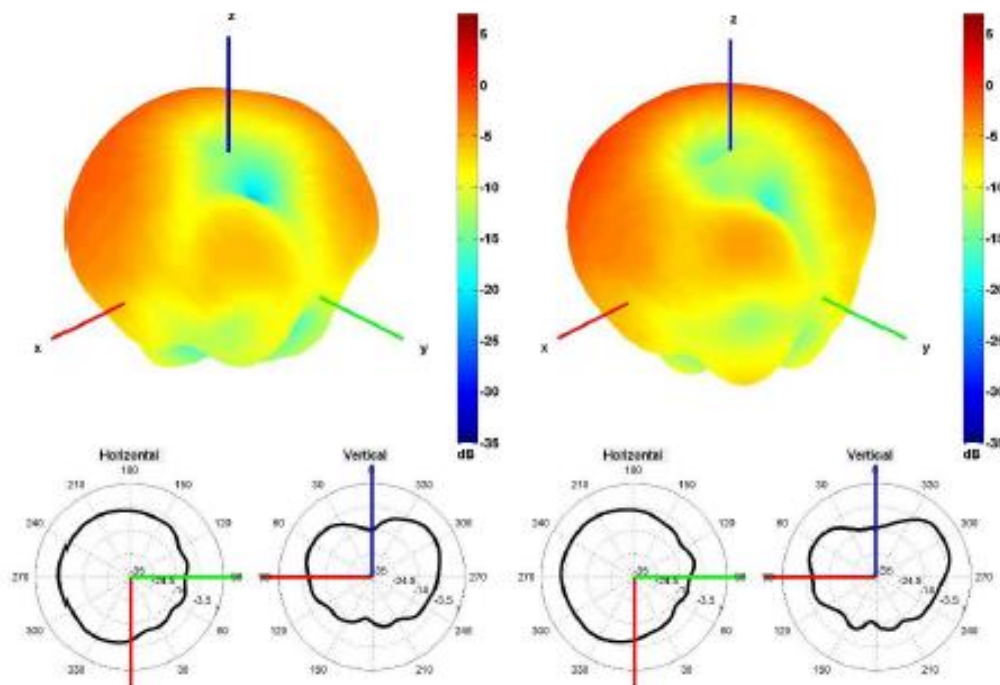

1500 and 1600 MHz Radiation pattern

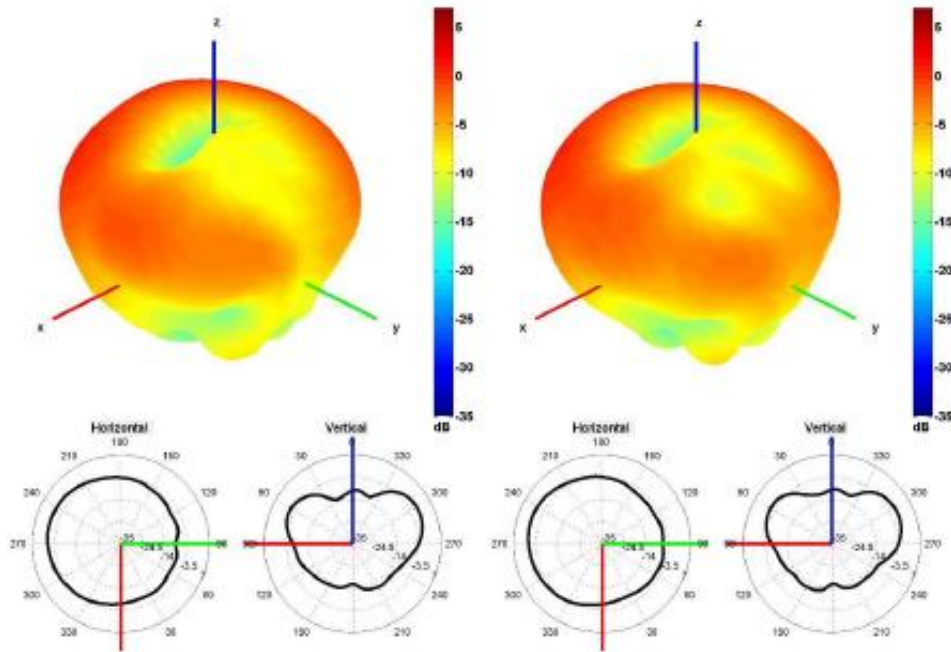

1750 and 1850 MHz Radiation pattern

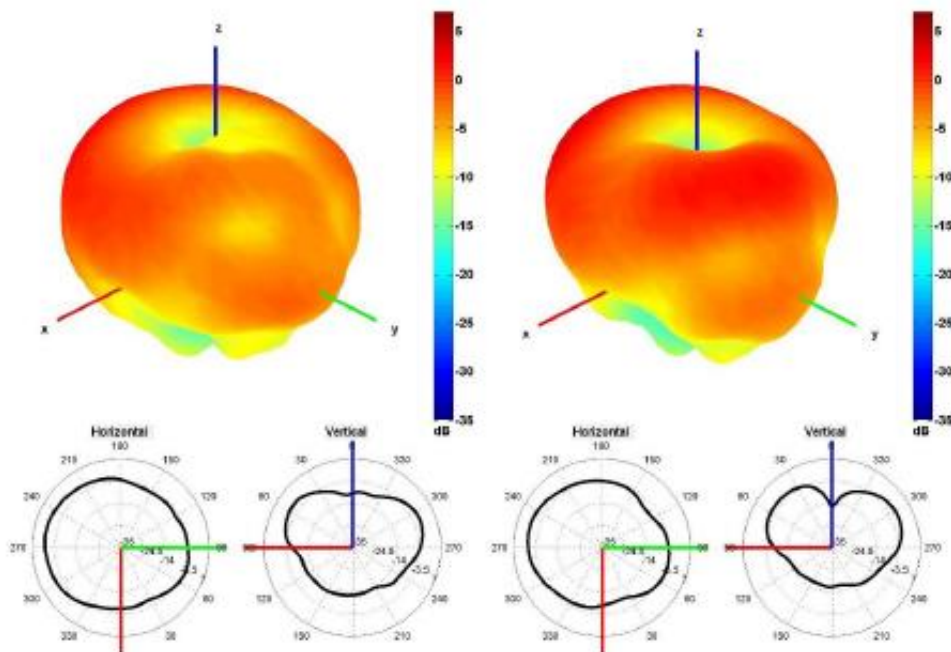

1950 and 2100 MHz Radiation pattern

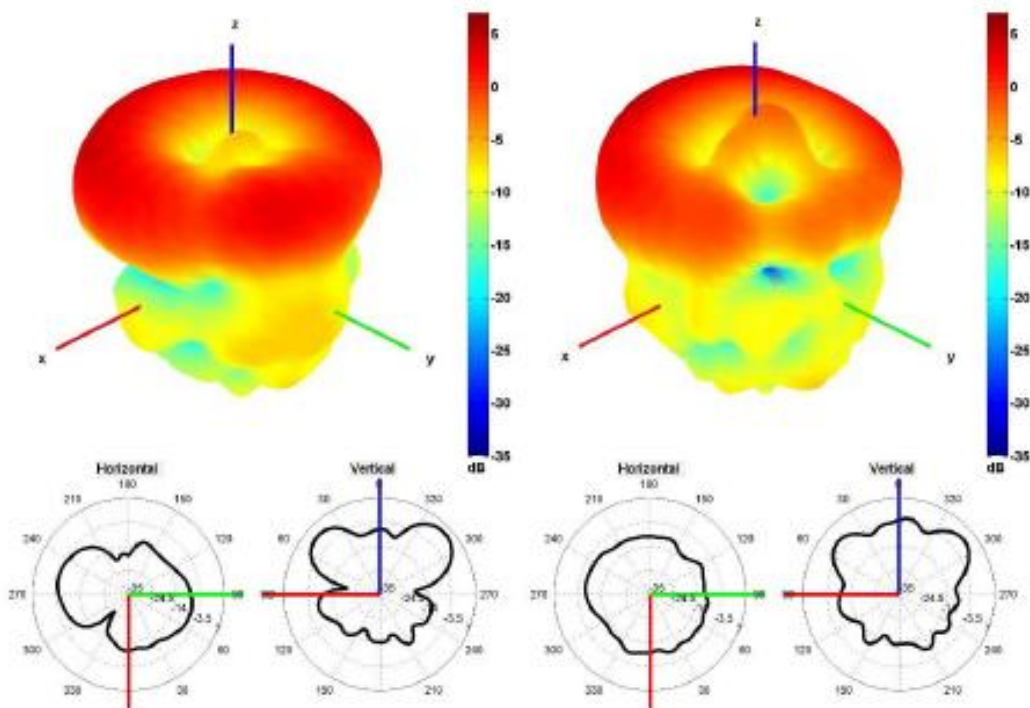

2350 and 2600 MHz Radiation pattern

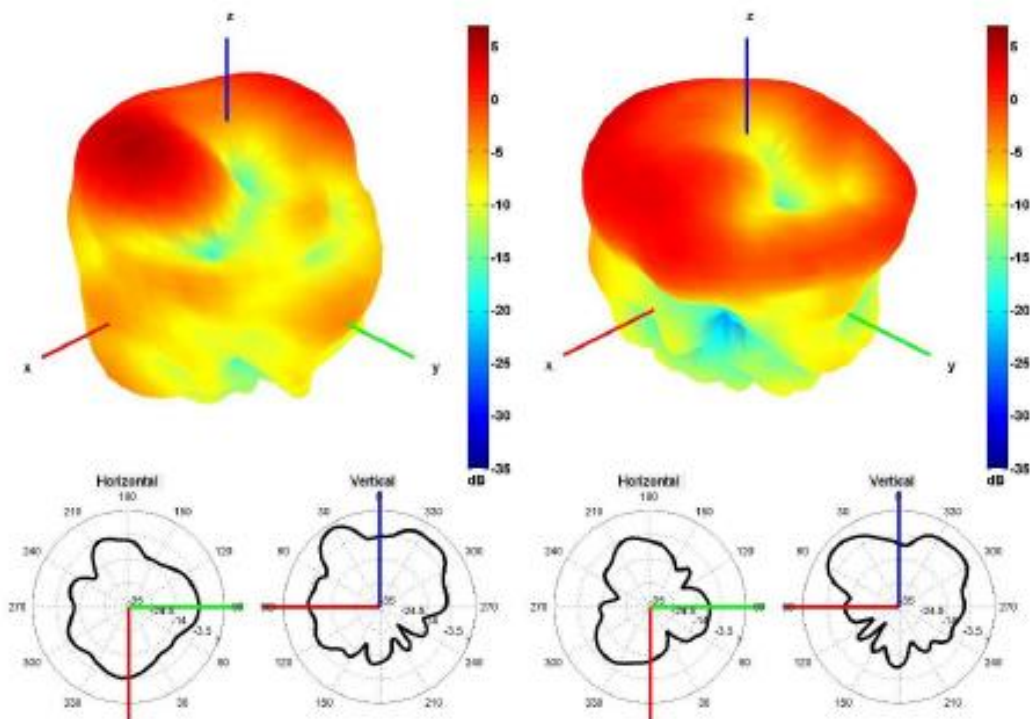

3350 and 3600 MHz Radiation pattern

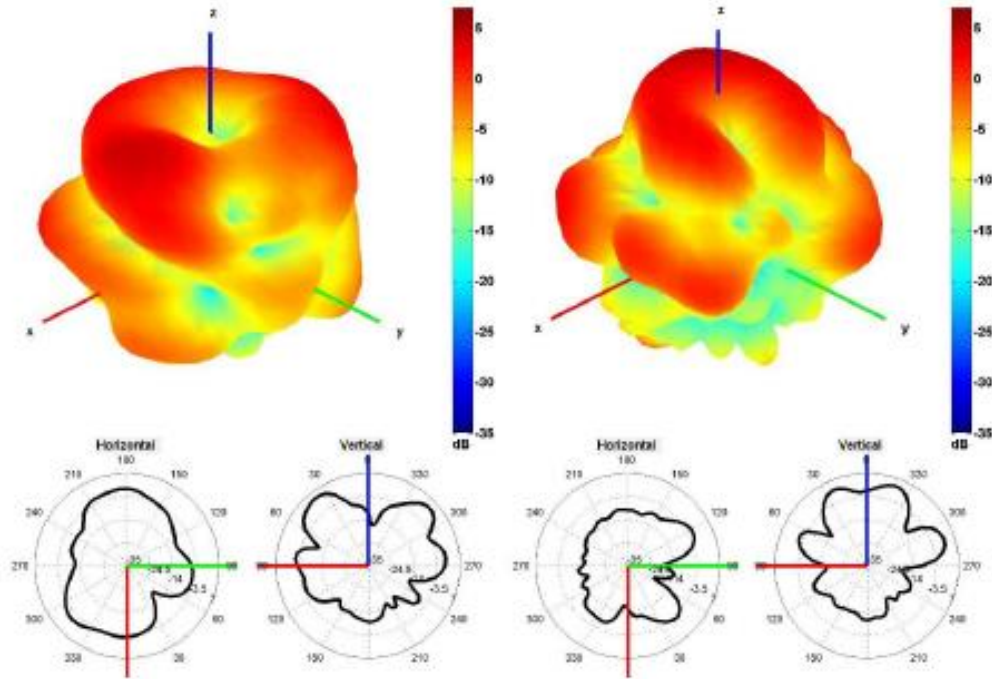

4500 and 5500 MHz Radiation pattern

Table 2: 5GNR

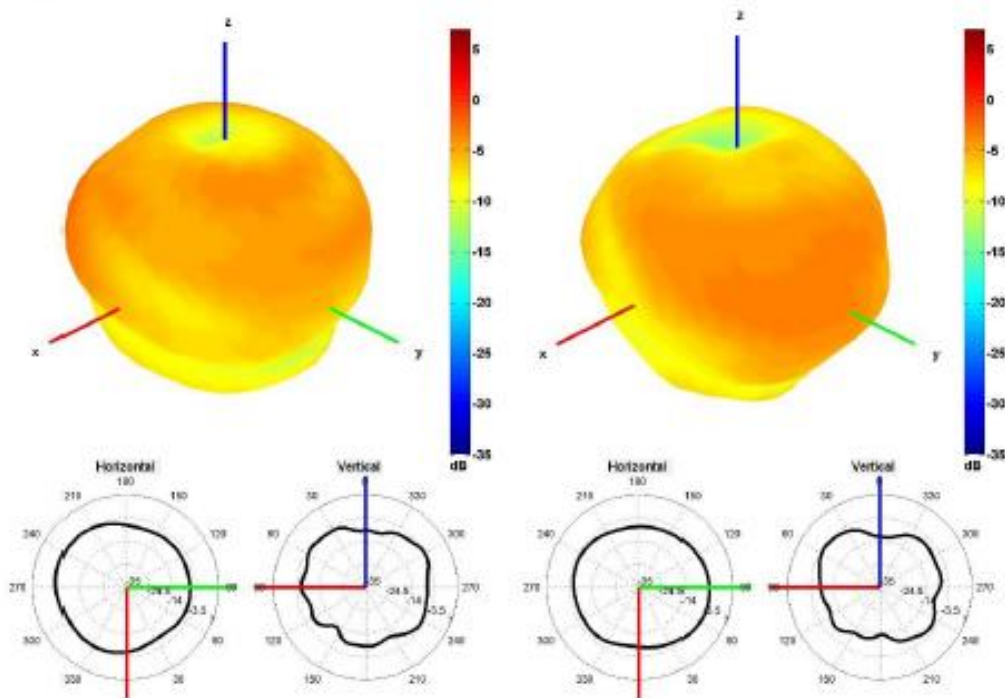

650 and 750 MHz Radiation pattern

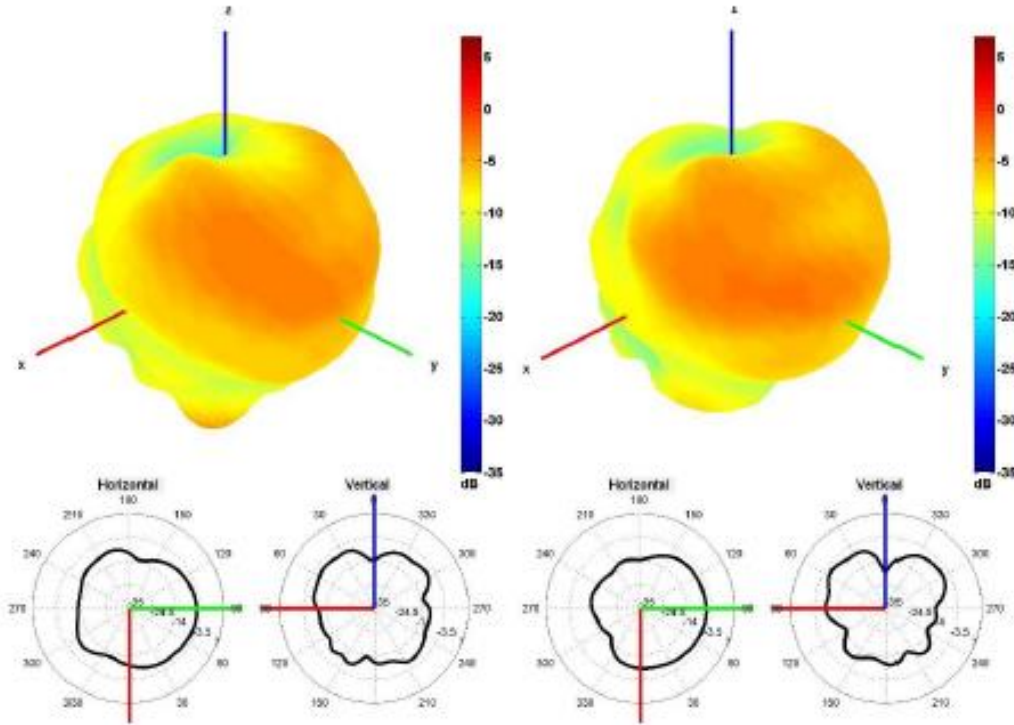

850 and 940 MHz Radiation pattern

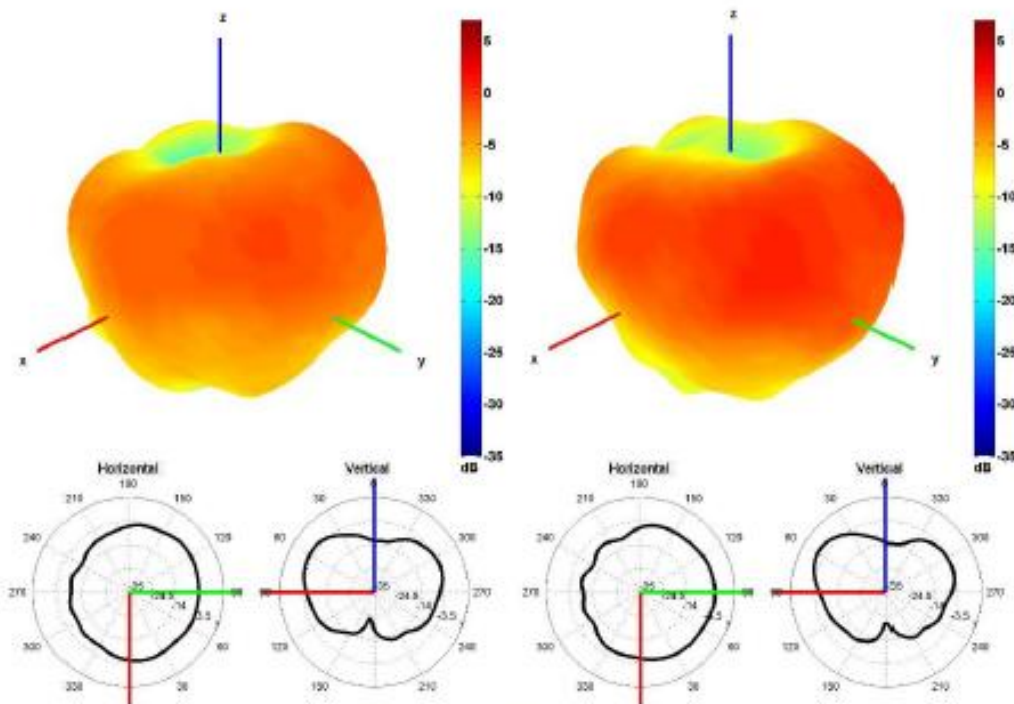

1500 and 1600 MHz Radiation pattern

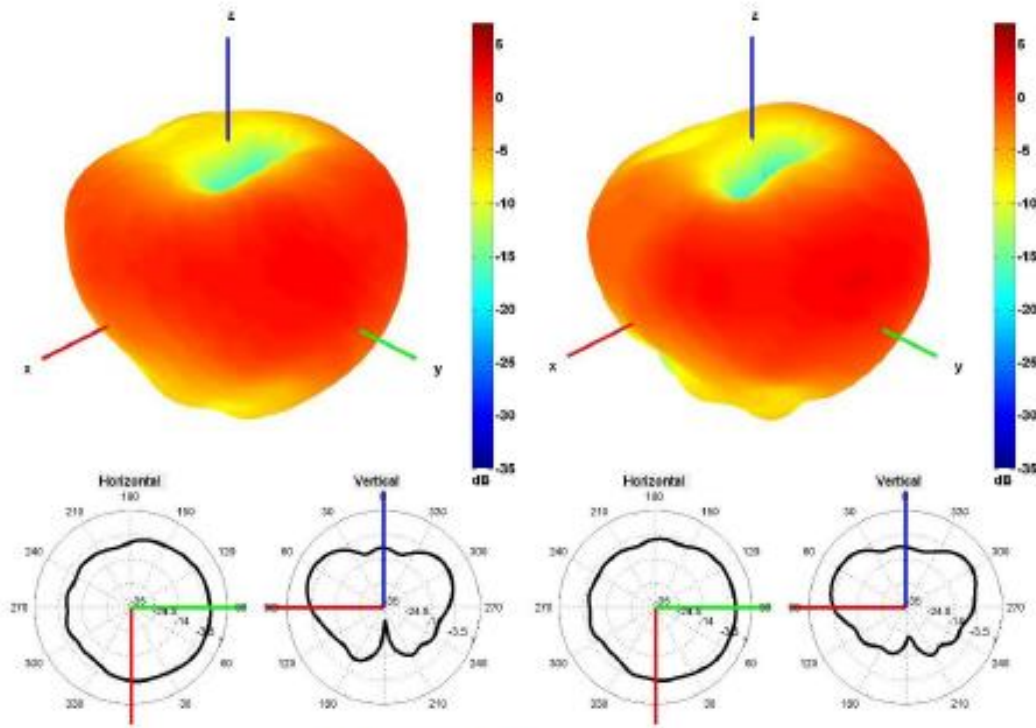

1750 and 1850 MHz Radiation pattern

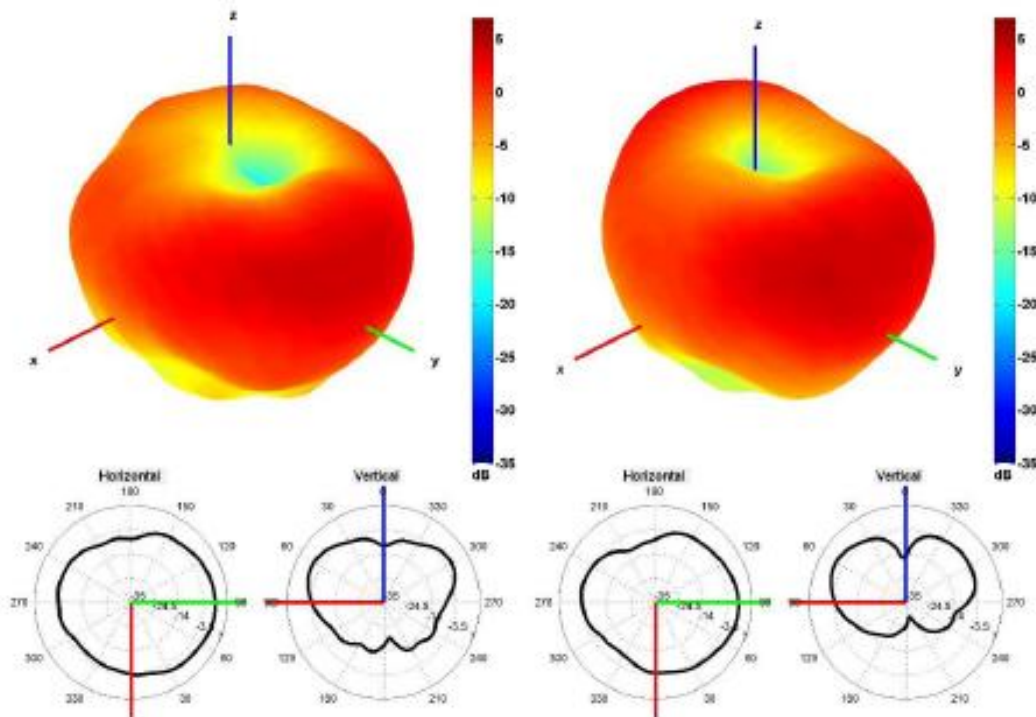

1950 and 2100 MHz Radiation pattern

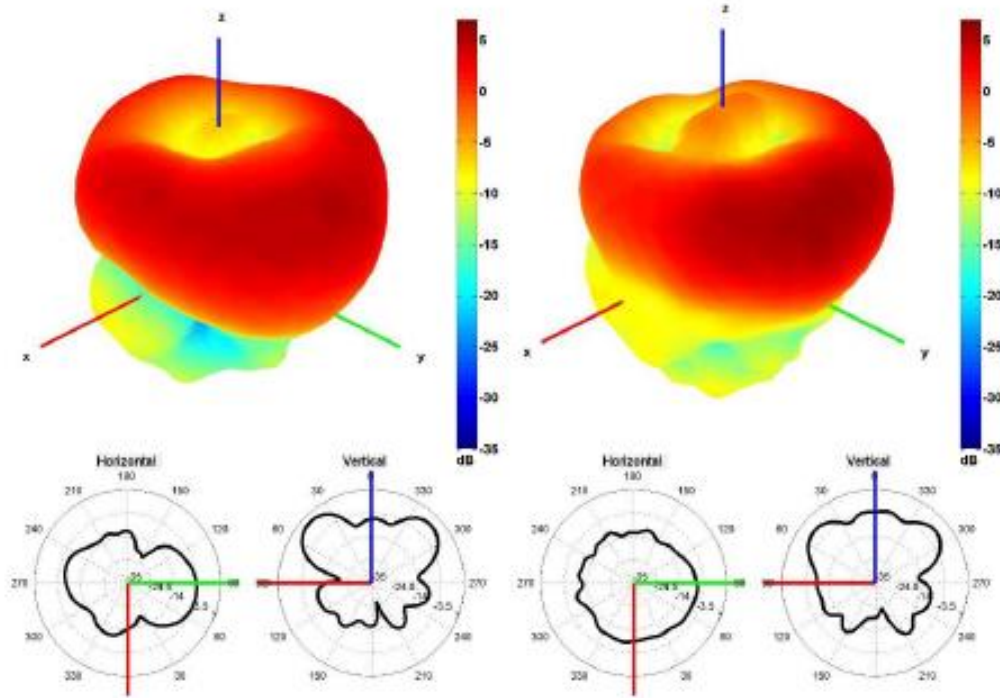

2350 and 2600 MHz Radiation pattern

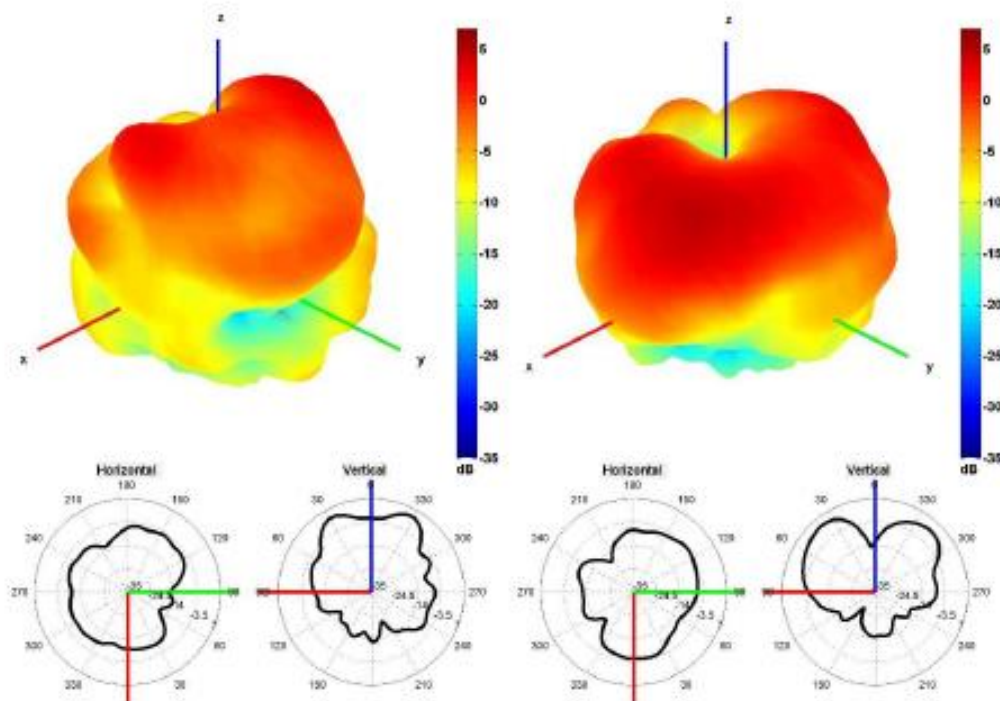

3350 and 3600 MHz Radiation pattern

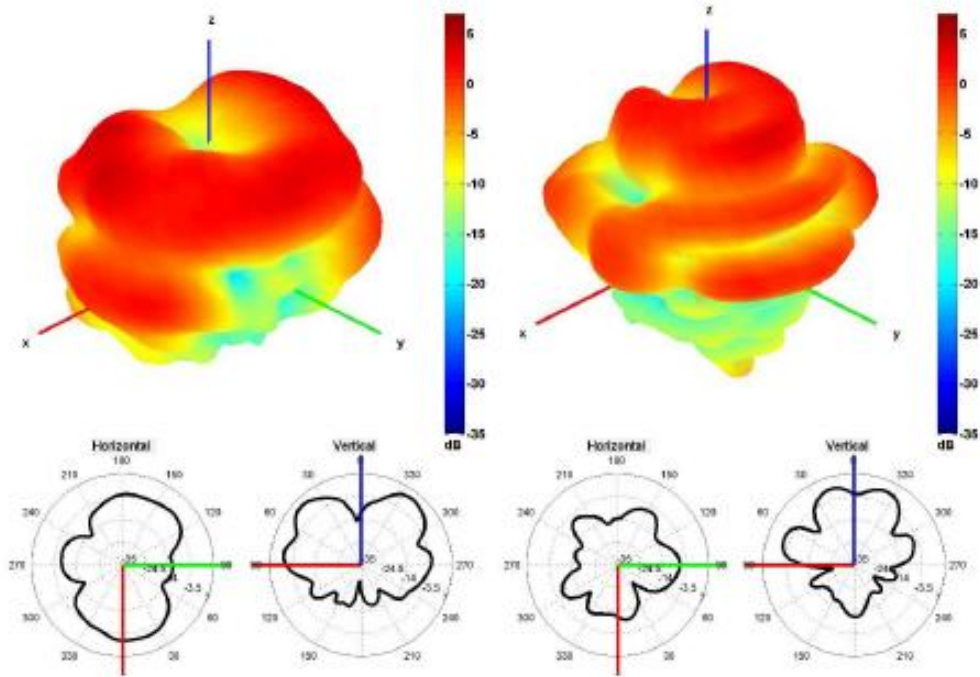

4500 and 5500 MHz Radiation pattern

Cable 3: 5GNR

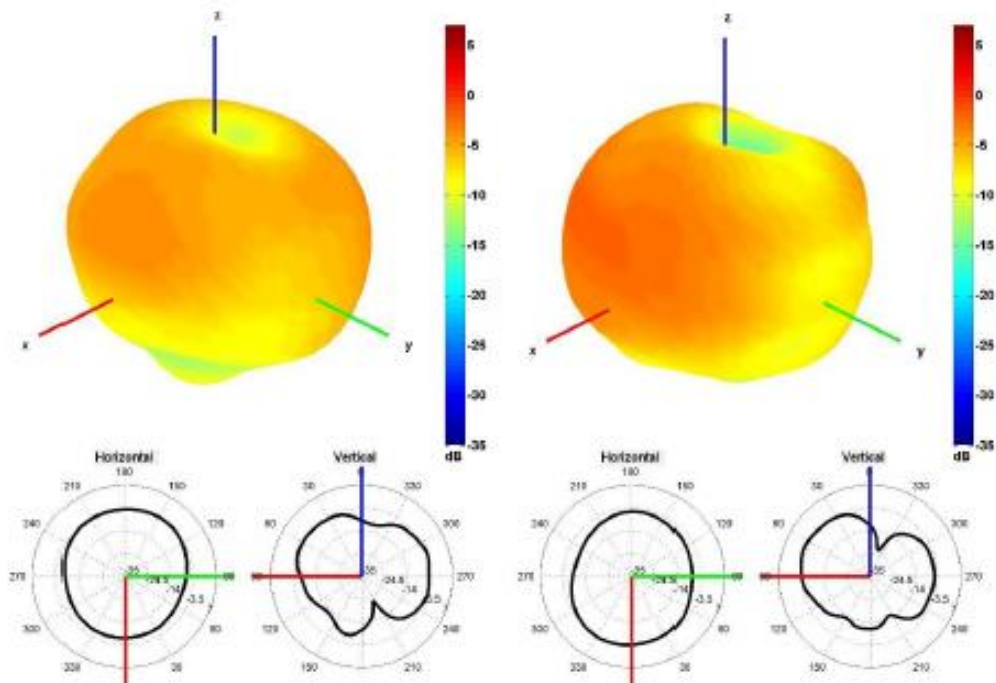

650 and 750 MHz Radiation pattern

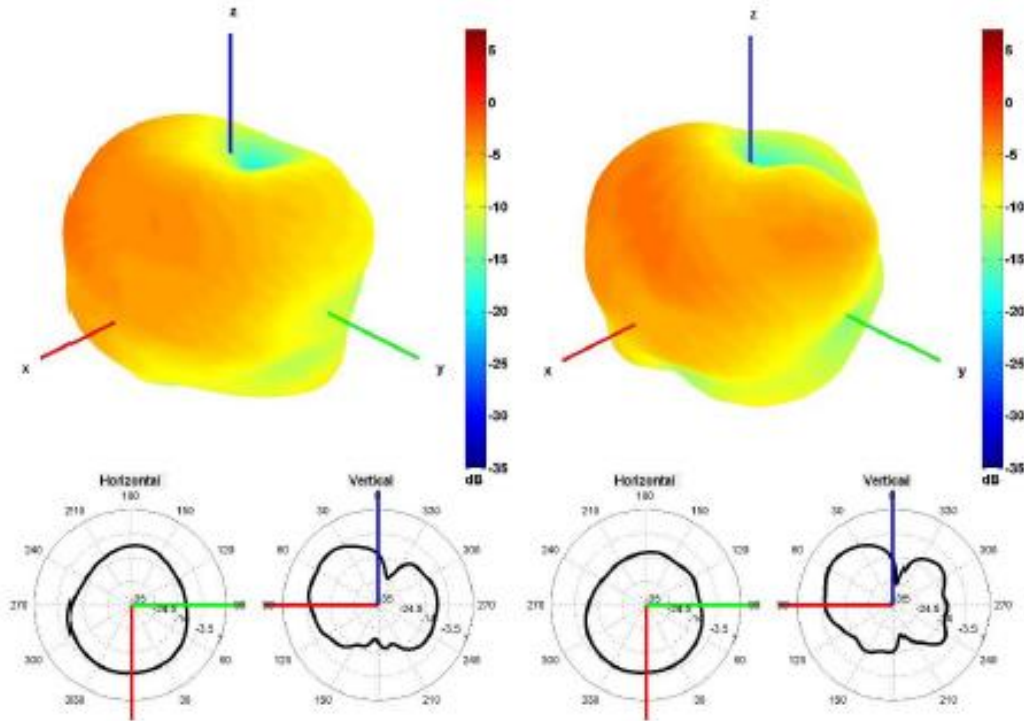

850 and 940 MHz Radiation pattern

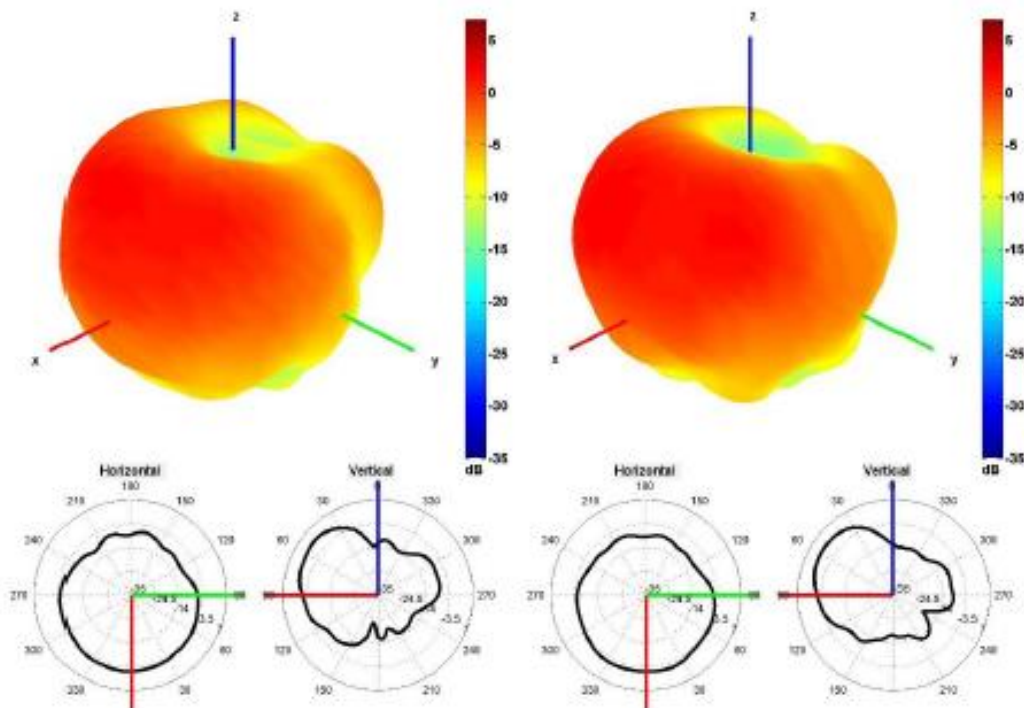

1500 and 1600 MHz Radiation pattern

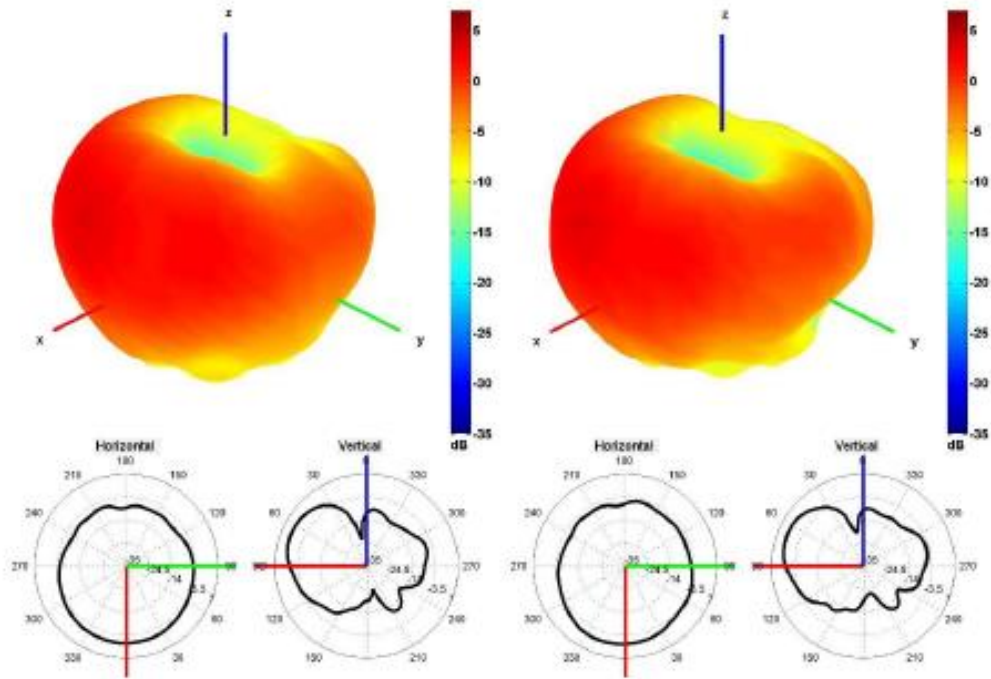

1750 and 1850 MHz Radiation pattern

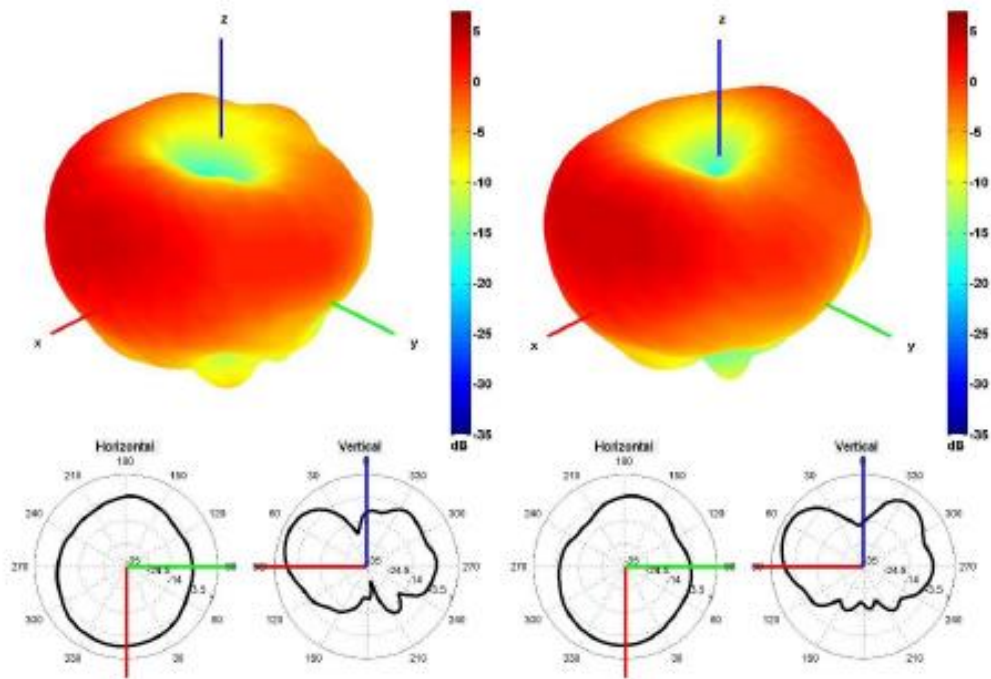

1950 and 2100 MHz Radiation pattern

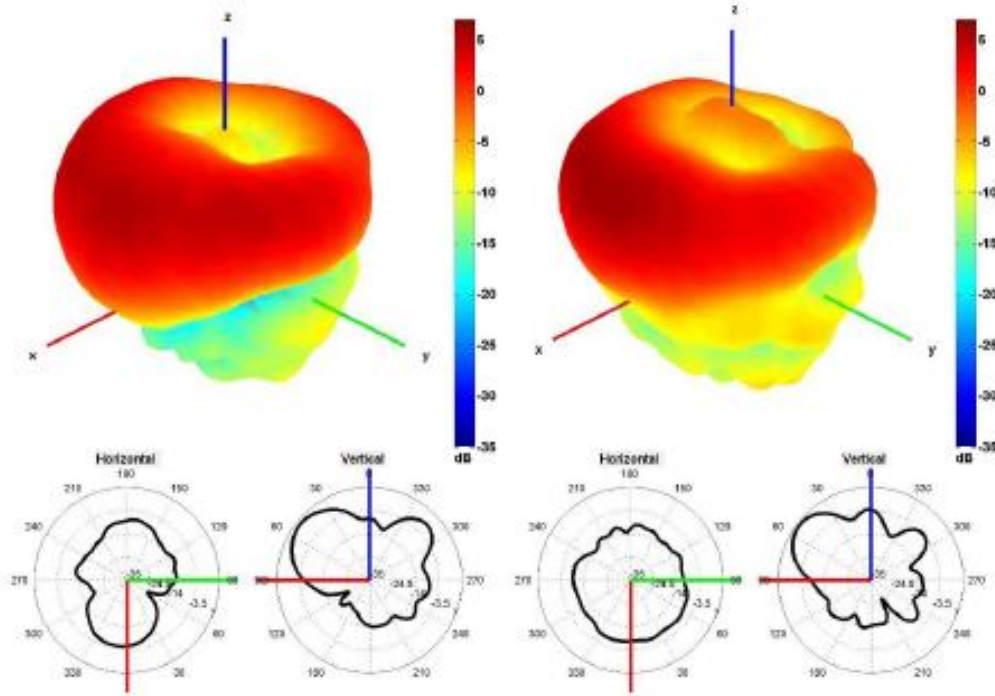

2350 and 2600 MHz Radiation pattern

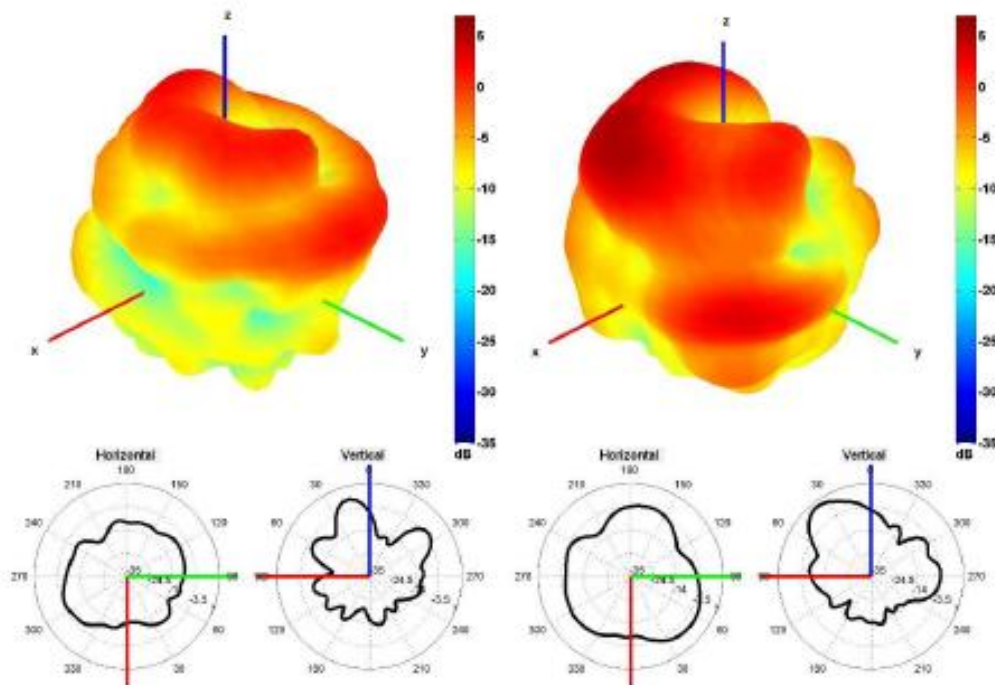

3350 and 3600 MHz Radiation pattern

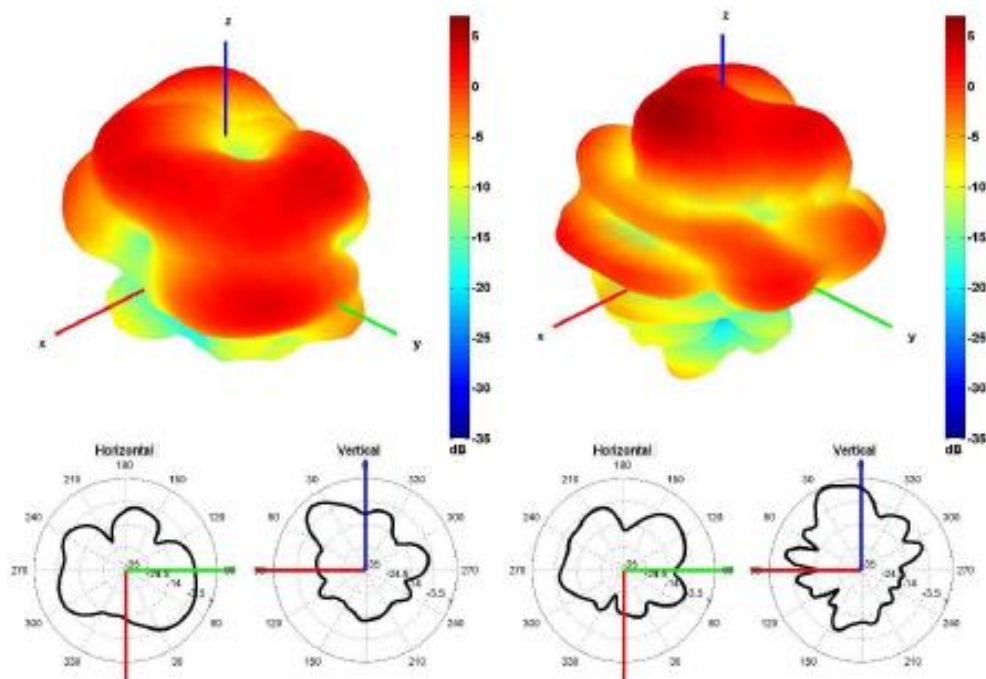

450 and 550 MHz Radiation pattern

Table 4: 5GNR

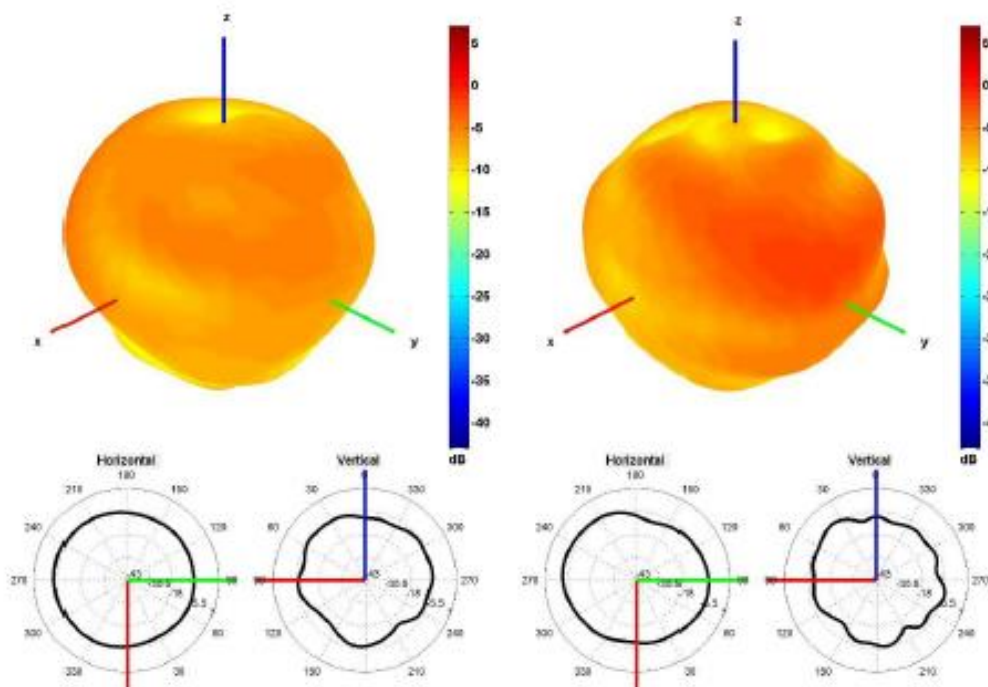

650 and 750 MHz Radiation pattern

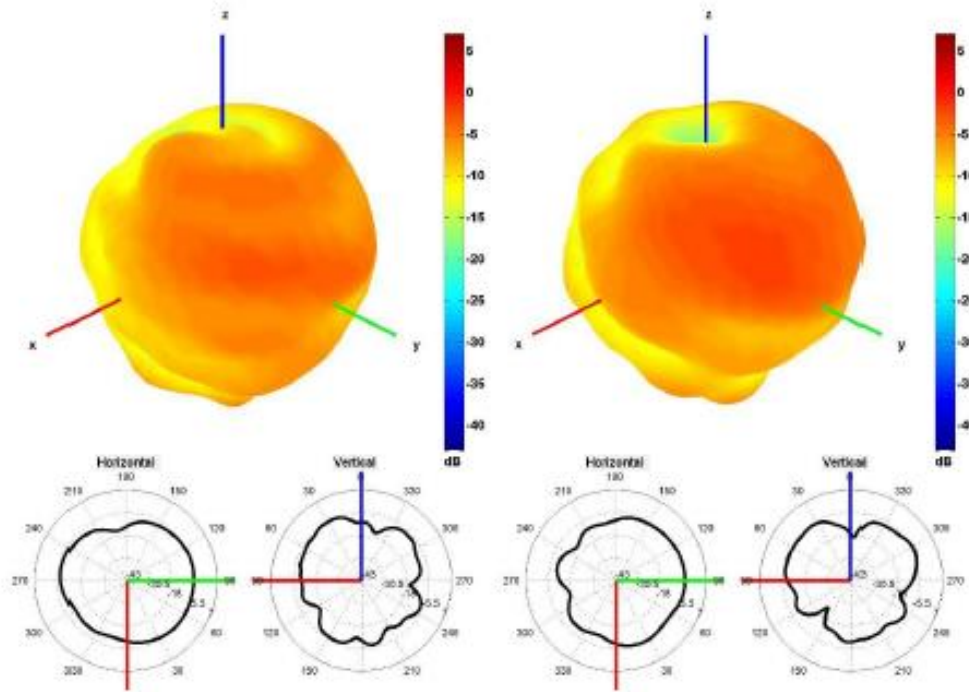

850 and 940 MHz Radiation pattern

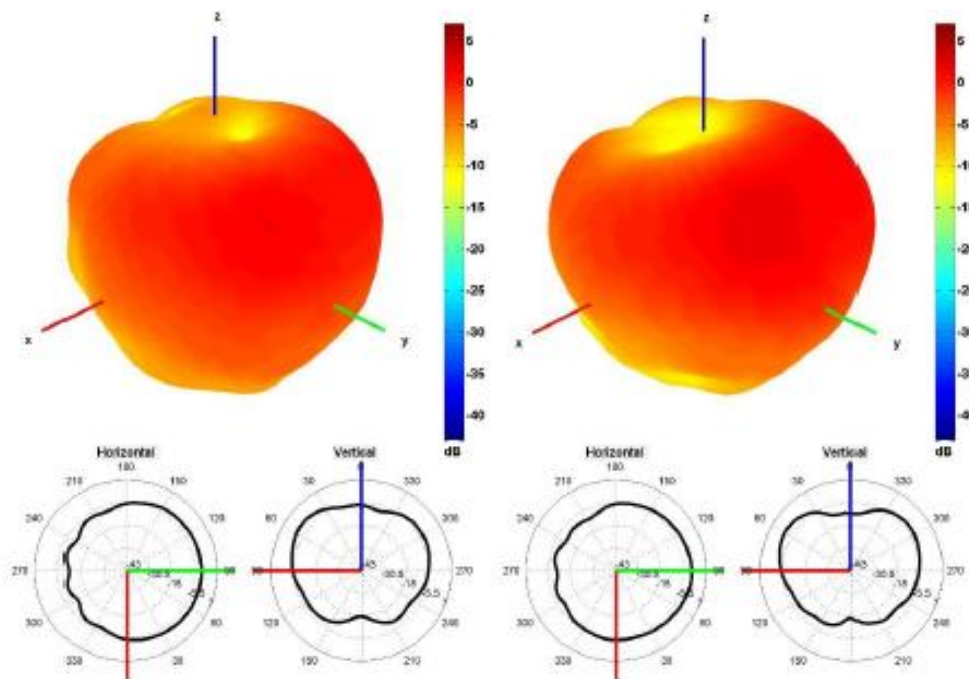

1500 and 1600 MHz Radiation pattern

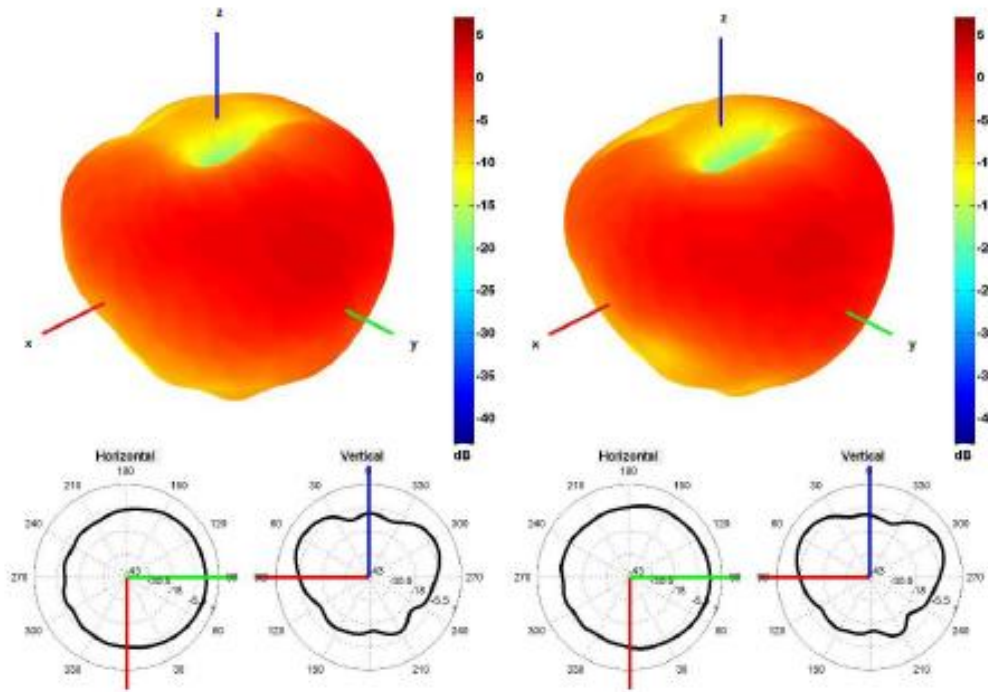

1750 and 1850 MHz Radiation pattern

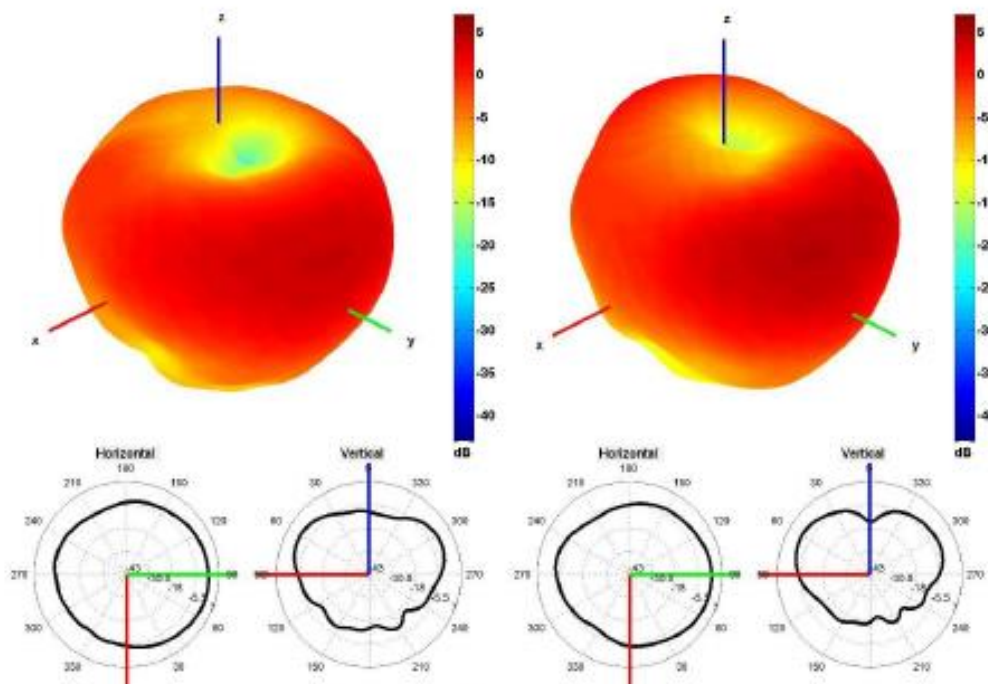

1950 and 2100 MHz Radiation pattern

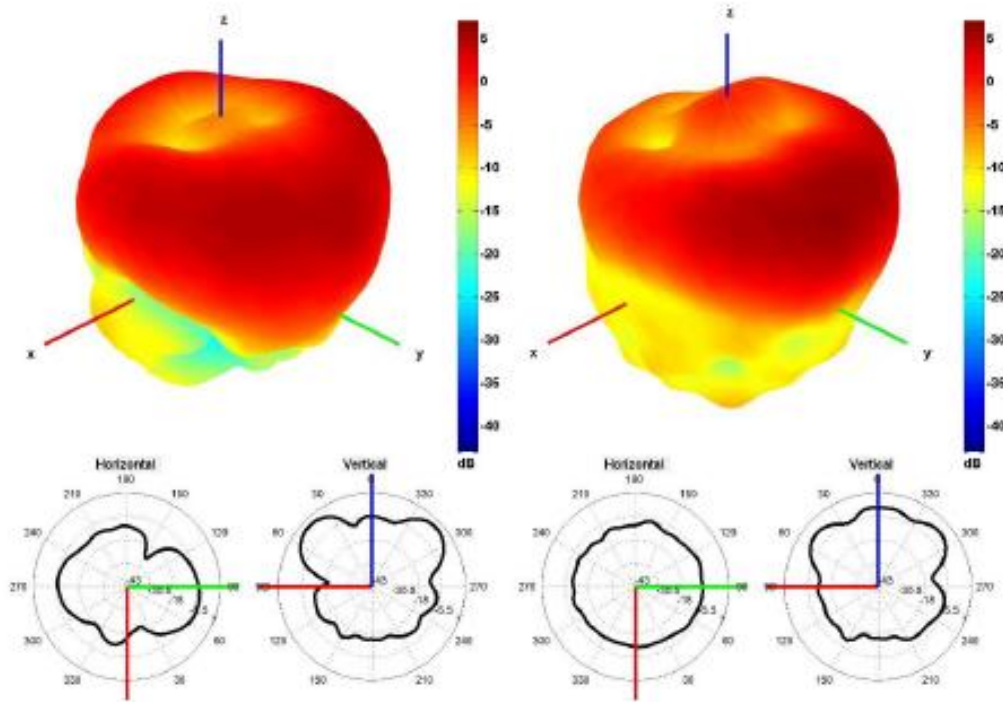

2350 and 2600 MHz Radiation pattern

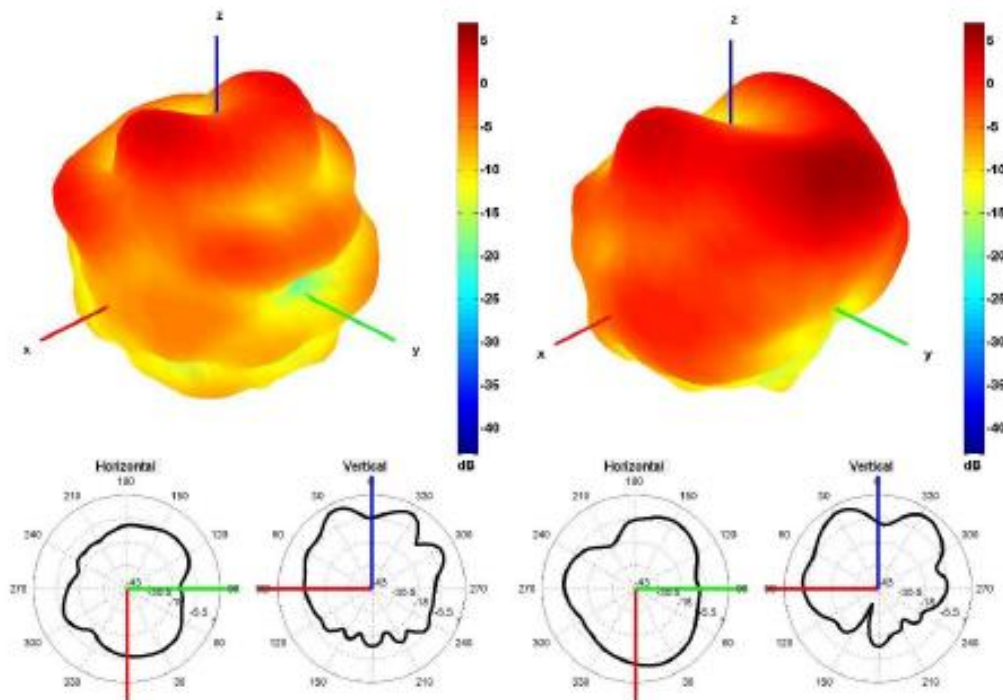

3350 and 3600 MHz Radiation pattern

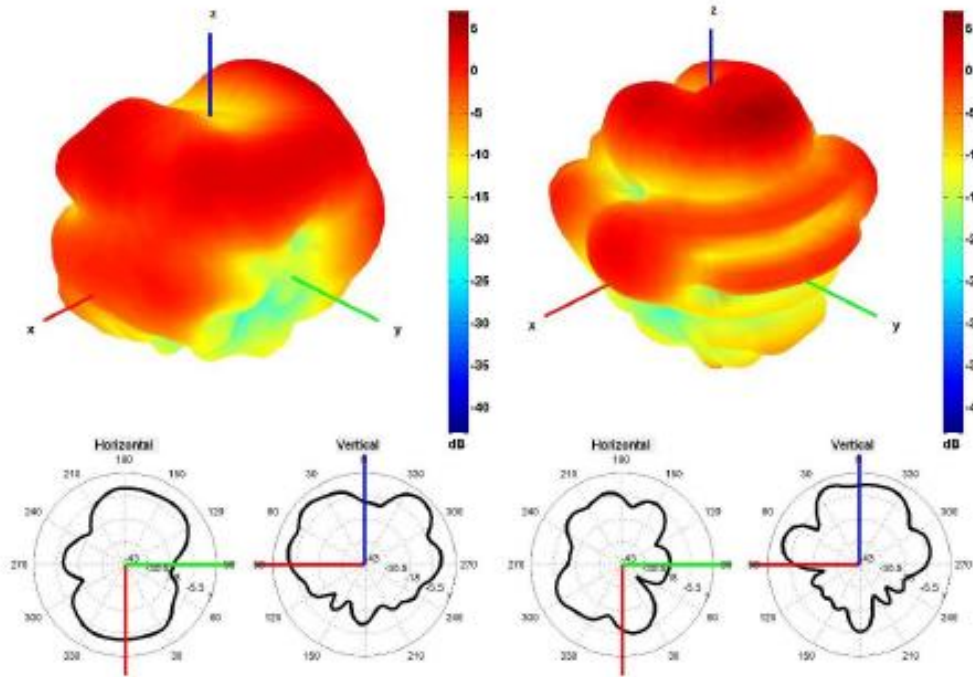

450 and 550 MHz Radiation pattern