



AirPrime HL7518

Product Technical Specification



SIERRA
WIRELESS®

4115834
14.0
June 11, 2019

Important Notice

Due to the nature of wireless communications, transmission and reception of data can never be guaranteed. Data may be delayed, corrupted (i.e., have errors) or be totally lost. Although significant delays or losses of data are rare when wireless devices such as the Sierra Wireless modem are used in a normal manner with a well-constructed network, the Sierra Wireless modem should not be used in situations where failure to transmit or receive data could result in damage of any kind to the user or any other party, including but not limited to personal injury, death, or loss of property. Sierra Wireless accepts no responsibility for damages of any kind resulting from delays or errors in data transmitted or received using the Sierra Wireless modem, or for failure of the Sierra Wireless modem to transmit or receive such data.

Safety and Hazards

Do not operate the Sierra Wireless modem in areas where cellular modems are not advised without proper device certifications. These areas include environments where cellular radio can interfere such as explosive atmospheres, medical equipment, or any other equipment which may be susceptible to any form of radio interference. The Sierra Wireless modem can transmit signals that could interfere with this equipment. Do not operate the Sierra Wireless modem in any aircraft, whether the aircraft is on the ground or in flight. In aircraft, the Sierra Wireless modem **MUST BE POWERED OFF**. When operating, the Sierra Wireless modem can transmit signals that could interfere with various onboard systems.

Note: Some airlines may permit the use of cellular phones while the aircraft is on the ground and the door is open. Sierra Wireless modems may be used at this time.

The driver or operator of any vehicle should not operate the Sierra Wireless modem while in control of a vehicle. Doing so will detract from the driver or operator's control and operation of that vehicle. In some states and provinces, operating such communications devices while in control of a vehicle is an offence.

Limitations of Liability

This manual is provided "as is". Sierra Wireless makes no warranties of any kind, either expressed or implied, including any implied warranties of merchantability, fitness for a particular purpose, or noninfringement. The recipient of the manual shall endorse all risks arising from its use.

The information in this manual is subject to change without notice and does not represent a commitment on the part of Sierra Wireless. SIERRA WIRELESS AND ITS AFFILIATES SPECIFICALLY DISCLAIM LIABILITY FOR ANY AND ALL DIRECT, INDIRECT, SPECIAL, GENERAL, INCIDENTAL, CONSEQUENTIAL, PUNITIVE OR EXEMPLARY DAMAGES INCLUDING, BUT NOT LIMITED TO, LOSS OF PROFITS OR REVENUE OR ANTICIPATED PROFITS OR REVENUE ARISING OUT OF THE USE OR INABILITY TO USE ANY SIERRA WIRELESS PRODUCT, EVEN IF SIERRA WIRELESS AND/OR ITS AFFILIATES HAS BEEN ADVISED OF THE POSSIBILITY OF SUCH DAMAGES OR THEY ARE FORESEEABLE OR FOR CLAIMS BY ANY THIRD PARTY.

Notwithstanding the foregoing, in no event shall Sierra Wireless and/or its affiliates aggregate liability arising under or in connection with the Sierra Wireless product, regardless of the number of events, occurrences, or claims giving rise to liability, be in excess of the price paid by the purchaser for the Sierra Wireless product.

Patents

This product may contain technology developed by or for Sierra Wireless Inc.

This product is manufactured or sold by Sierra Wireless Inc. or its affiliates under one or more patents licensed from MMP Portfolio Licensing.

Copyright

© 2019 Sierra Wireless. All rights reserved.

Trademarks

Sierra Wireless®, AirPrime®, AirLink®, AirVantage®, WISMO®, ALEOS® and the Sierra Wireless and Open AT logos are registered trademarks of Sierra Wireless, Inc. or one of its subsidiaries.

Watcher® is a registered trademark of NETGEAR, Inc., used under license.

Windows® and Windows Vista® are registered trademarks of Microsoft Corporation.

Macintosh® and Mac OS X® are registered trademarks of Apple Inc., registered in the U.S. and other countries.

QUALCOMM® is a registered trademark of QUALCOMM Incorporated. Used under license.

Other trademarks are the property of their respective owners.

Contact Information

Sales information and technical support, including warranty and returns	Web: sierrawireless.com/company/contact-us/ Global toll-free number: 1-877-687-7795 6:00 am to 5:00 pm PST
Corporate and product information	Web: sierrawireless.com

Document History

Version	Date	Updates
1.0	May 30, 2014	Creation
	June 05, 2014	<ul style="list-style-type: none"> Indicated that PCM pads are not available in Table 6 Pad Definition Updated: <ul style="list-style-type: none"> Table 6 Pad Definition Figure 3 Pad Configuration Table 20 Trace Debug Pad Description Section 5.8 ESD Guidelines for USB
		Removed: <ul style="list-style-type: none"> ADC section 5.6 Antenna Integration with Detection Circuit (due to the removal of ADC)
	June 16, 2014	Updated: <ul style="list-style-type: none"> 1.8.2 Regulatory 3.10 POWER-ON Signal (PWR_ON_N) 5.1 Power-Up Sequence 5.2 Module Switch-Off 7 FCC Legal Information
		Added 5.3 Emergency Power OFF
	September 16, 2014	Updated: <ul style="list-style-type: none"> 3.10 POWER-ON Signal (PWR_ON_N) 3.11 Reset Signal (RESET_IN_N) 5.1 Power-Up Sequence 5.2 Module Switch-Off
September 26, 2014	Updated: <ul style="list-style-type: none"> 2 Pad Definition 3.5 SIM Interface 3.13.1 Trace Debug 	
1.1	October 06, 2014	Removed unsupported AT commands throughout the document.
		Updated Table 8 Current Consumption
1.2	November 10, 2014	Updated: <ul style="list-style-type: none"> Table 2 General Features Table 8 Current Consumption
	December 01, 2014	Updated: <ul style="list-style-type: none"> 2 Pad Definition Table 9 VGPIO Electrical Characteristics Figure 10 EMC and ESD Components Close to the SIM
		Deleted section 6 X-Ray Exposure
1.3	December 05, 2014	Updated Figure 3 Pad Configuration
1.4	January 08, 2015	Updated: <ul style="list-style-type: none"> 1.7 ESD The note in section 3.2 Current Consumption

Version	Date	Updates
2.0	July 09, 2015	Updated: <ul style="list-style-type: none"> Signal names from PWR_ON to PWR_ON_N, and RESET_IN to RESET_IN_N Figure 2 Mechanical Overview Table 6 Pad Definition Figure 7 PWR_ON_N Sequence with VGPIO Information
2.1	July 20, 2015	Updated: <ul style="list-style-type: none"> Table 6 Pad Definition Signal name from MIPI2_TRACE_CLK to TRACE_CLK
2.2	August 06, 2015	Updated: <ul style="list-style-type: none"> Table 6 Pad Definition 3.2 Current Consumption Figure 7 PWR_ON_N Sequence with VGPIO Information
2.3	August 21, 2015	Updated AT command to use from +CPOF to +CPWROFF
3.0	November 19, 2015	Updated: <ul style="list-style-type: none"> Note in section 3 Detailed Interface Specifications Table 7 Power Supply
4.0	December 24, 2015	Added 6 Reliability Specification
5.0	July 25, 2016	Added: <ul style="list-style-type: none"> In-rush current in 5.1 Power-Up Sequence 5.5 Power Supply Design
		Updated: <ul style="list-style-type: none"> Figure 2 Mechanical Overview 4 Mechanical Drawings Table 32 Ordering Information
6.0	October 03, 2016	Added a note after Table 16 UART1 Pad Description
		Updated PWR_ON_N pull up resistor value from 47kΩ to 100kΩ
7.0	February 14, 2017	Updated Protocol Stack row in Table 2 General Features
8.0	July 07, 2017	Updated: <ul style="list-style-type: none"> Table 1 Supported Bands/Connectivity Table 14 Digital I/O Electrical Characteristics
9.0	August 28, 2017	Updated note below Table 13 USB Pad Description
		Deleted HSIC
10.0	November 14, 2017	Added 5.4 Sleep Mode Management
11.0	February 09, 2018	Added 5.6 Power Cycle
12.0	July 03, 2018	Added 3.13.3 USB
		Updated: <ul style="list-style-type: none"> 1.8.3 RoHS Directive Compliance Table 6 Pad Definition 3.14 RF Interface
12.1	July 19, 2018	Removed unavailable UIM2 pins.
13.0	January 02, 2019	Updated: <ul style="list-style-type: none"> Table 2 General Features 3.13 Debug Interfaces
14.0	June 11, 2019	Updated 3.13.2 JTAG

»» Contents

1. INTRODUCTION	10
1.1. Common Flexible Form Factor (CF ³)	10
1.2. Physical Dimensions	10
1.3. General Features	11
1.4. Architecture	12
1.5. Interfaces	13
1.6. Connection Interface	13
1.7. ESD	14
1.8. Environmental and Certifications	14
1.8.1. Environmental Specifications	14
1.8.2. Regulatory	15
1.8.3. RoHS Directive Compliance	15
1.8.4. Disposing of the Product	15
1.9. References	15
2. PAD DEFINITION	16
2.1. Pad Configuration (Top View, Through Module)	21
3. DETAILED INTERFACE SPECIFICATIONS	22
3.1. Power Supply	22
3.2. Current Consumption	22
3.3. VGPIO	23
3.4. BAT_RTC	23
3.5. SIM Interface	24
3.5.1. UIM1_DET	24
3.6. USB	25
3.7. Electrical Information for Digital I/O	25
3.8. General Purpose Input/Output (GPIO)	26
3.9. Main Serial Link (UART1)	26
3.10. POWER-ON Signal (PWR_ON_N)	27
3.11. Reset Signal (RESET_IN_N)	28
3.12. Clock Interface	28
3.13. Debug Interfaces	29
3.13.1. USB	29
3.13.2. JTAG	29
3.13.3. Trace Debug	30
3.14. RF Interface	30
3.14.1. RF Connection	30
3.14.2. RF Performances	31

4. MECHANICAL DRAWINGS	32
5. DESIGN GUIDELINES	35
5.1. Power-Up Sequence	35
5.2. Module Switch-Off	36
5.3. Emergency Power OFF	36
5.4. Sleep Mode Management	36
5.4.1. Using UART1	36
5.4.2. Using USB	37
5.5. Power Supply Design	37
5.6. Power Cycle	37
5.7. ESD Guidelines for SIM Card	37
5.8. ESD Guidelines for USB	38
6. RELIABILITY SPECIFICATION	39
6.1. Reliability Compliance	39
6.2. Reliability Prediction Model	39
6.2.1. Life Stress Test	39
6.2.2. Environmental Resistance Stress Tests	40
6.2.3. Corrosive Resistance Stress Tests	40
6.2.4. Thermal Resistance Cycle Stress Tests	41
6.2.5. Mechanical Resistance Stress Tests	42
6.2.6. Handling Resistance Stress Tests	43
7. FCC LEGAL INFORMATION	44
8. ORDERING INFORMATION	46
9. TERMS AND ABBREVIATIONS	47



List of Figures

Figure 1.	Architecture Overview	12
Figure 2.	Mechanical Overview	13
Figure 3.	Pad Configuration.....	21
Figure 4.	Mechanical Drawing	32
Figure 5.	Dimensions Drawing	33
Figure 6.	Footprint	34
Figure 7.	PWR_ON_N Sequence with VGPIO Information.....	35
Figure 8.	Power OFF Sequence for PWR_ON_N, VGPIO.....	36
Figure 9.	Voltage Limiter Example	37
Figure 10.	EMC and ESD Components Close to the SIM.....	38
Figure 11.	ESD Protection for USB	38

List of Tables

Table 1.	Supported Bands/Connectivity	10
Table 2.	General Features	11
Table 3.	ESD Specifications	14
Table 4.	Environmental Specifications	14
Table 5.	Regulation Compliance	15
Table 6.	Pad Definition	16
Table 7.	Power Supply	22
Table 8.	Current Consumption	22
Table 9.	VGPIIO Electrical Characteristics.....	23
Table 10.	BAT_RTC Electrical Characteristics.....	23
Table 11.	UIM1 Pad Description	24
Table 12.	Electrical Characteristics of UIM1	24
Table 13.	USB Pad Description.....	25
Table 14.	Digital I/O Electrical Characteristics	25
Table 15.	GPIO Pad Description	26
Table 16.	UART1 Pad Description	27
Table 17.	PWR_ON_N Electrical Characteristics	27
Table 18.	RESET_IN_N Electrical Characteristics.....	28
Table 19.	Clock Interface Pad Description	28
Table 20.	USB Pad Description.....	29
Table 21.	JTAG Pad Description	29
Table 22.	Trace Debug Pad Description	30
Table 23.	RF Main Connection.....	30
Table 24.	RF Diversity Connection.....	30
Table 25.	Conducted RX Sensitivity (dBm).....	31
Table 26.	Standards Conformity.....	39
Table 27.	Life Stress Test.....	39
Table 28.	Environmental Resistance Stress Tests	40
Table 29.	Corrosive Resistance Stress Tests	40
Table 30.	Thermal Resistance Cycle Stress Tests	41
Table 31.	Mechanical Resistance Stress Tests	42
Table 32.	Handling Resistance Stress Tests	43
Table 33.	Ordering Information	46

1. Introduction

This document is the Product Technical Specification for the AirPrime HL7518 Embedded Module. It defines the high-level product features and illustrates the interfaces for these features. This document is intended to cover the hardware aspects of the product, including electrical and mechanical.

The AirPrime HL7518 belongs to the AirPrime HL Series from Essential Connectivity Module family. These are industrial grade Embedded Wireless Modules that provides data connectivity on LTE networks (as listed in Table 1 Supported Bands/Connectivity).

The HL7518 supports a large variety of interfaces such as USB 2.0, UART and GPIOs to provide customers with the highest level of flexibility in implementing high-end solutions.

Table 1. Supported Bands/Connectivity

RF Band	Transmit Band (Tx)	Receive Band (Rx)	Maximum Output Power
LTE B4	1710 to 1755 MHz	2110 to 2155 MHz	23 dBm (± 2 dBm) Class 3bis
LTE B13	777 to 787 MHz	746 to 756 MHz	23 dBm (± 2 dBm) Class 3bis

1.1. Common Flexible Form Factor (CF³)

The AirPrime HL7518 belongs to the Common Flexible Form Factor (CF³) family of modules. This family consists of a series of WWAN modules that share the same mechanical dimensions (same width and length with varying thicknesses) and footprint. The CF³ form factor provides a unique solution to a series of problems faced commonly in the WWAN module space as it:

- Accommodates multiple radio technologies (from 2G to LTE advanced) and band groupings
- Supports bit-pipe (Essential Module Series) and value add (Smart Module Series) solutions
- Offers electrical and functional compatibility
- Provides Direct Mount as well as Socketability depending on customer needs

1.2. Physical Dimensions

AirPrime HL7518 modules are compact, robust, fully shielded modules with the following dimensions:

- Length: 23 mm
- Width: 22 mm
- Thickness: 2.5 mm
- Weight: 3.5 g

Note: Dimensions specified above are typical values.

1.3. General Features

The table below summarizes the AirPrime HL7518 features.

Table 2. General Features

Feature	Description
Physical	<ul style="list-style-type: none"> • Small form factor (146-pad solderable LGA pad) – 23mm x 22mm x 2.5mm (nominal) • Complete body shielding • RF connection pads (RF main interface) • Baseband signals connection
Electrical	Single or double supply voltage (VBATT and VBATT_PA) – 3.2V – 4.5V
RF	Dual-band LTE (AWS (B4), 700 MHz (B13))
SIM interface	<ul style="list-style-type: none"> • Single SIM • 1.8V/3V support • SIM extraction / hot plug detection • SIM/USIM support • Conforms with ETSI UICC Specifications. • Supports SIM application tool kit with proactive SIM commands
Application interface	<ul style="list-style-type: none"> • NDIS NIC interface support (Windows XP, Windows 7, Windows 8, Windows CE, Linux) • Multiple non-multiplexed USB channel support • Dial-up networking • USB selective suspend to maximize power savings • CMUX multiplexing over UART • AT command interface – 3GPP 27.007 standard, plus proprietary extended AT commands
Protocol Stack	Single mode LTE operation: <ul style="list-style-type: none"> • LTE FDD, bandwidth 1.4-20 MHz • System Release: 3GPP Rel. 9 • Category 4 (up to 150 MBit/s in downlink, 50 MBit/s in uplink) • MIMO DL 2x2 • Max modulation 64 QAM DL, 16 QAM UL • Intra-frequency and inter-frequency mobility • SMS over SGs • SON ANR • Public Warning System PWS
SMS	<ul style="list-style-type: none"> • SMS over SGs and IMS • SMS MO and MT • SMS saving to SIM card or ME storage • SMS reading from SIM card or ME storage • SMS sorting • SMS concatenation • SMS Status Report • SMS replacement support • SMS storing rules (support of AT+CNMI, AT+CNMA)

Feature	Description
Connectivity	<ul style="list-style-type: none"> Multiple (up to 20) cellular packet data profiles Sleep mode for minimum idle power draw Mobile-originated PDP context activation / deactivation Support QoS profile <ul style="list-style-type: none"> Release 97 – Precedence Class, Reliability Class, Delay Class, Peak Throughput, Mean Throughput Release 99 QoS negotiation – Background, Interactive, and Streaming Static and Dynamic IP address. The network may assign a fixed IP address or dynamically assign one using DHCP (Dynamic Host Configuration Protocol). Supports PAP and CHAP authentication protocols PDP context type (IPv4, IPv6, IPv4v6). IP Packet Data Protocol context RFC1144 TCP/IP header compression
Environmental	Operating temperature ranges (industrial grade): <ul style="list-style-type: none"> Class A: -30°C to +70°C Class B: -40°C to +85°C
RTC	Real Time Clock (RTC) with calendar

1.4. Architecture

The figure below presents an overview of the AirPrime HL7518 internal architecture and external interfaces.

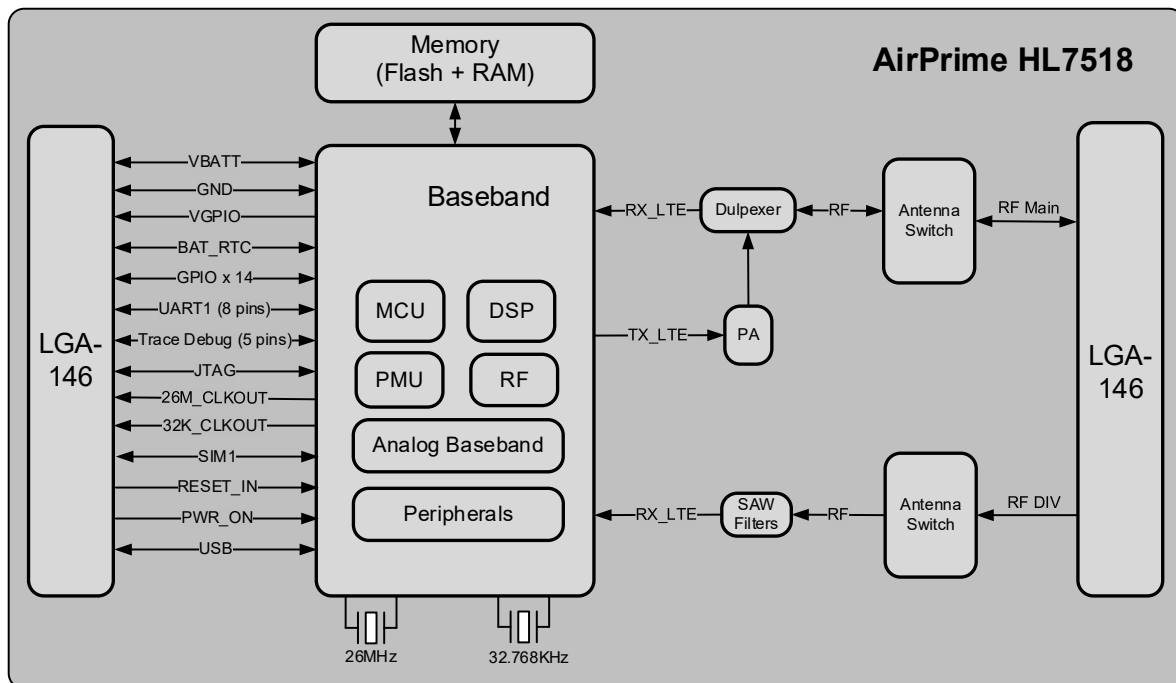

Figure 1. Architecture Overview

1.5. Interfaces

The AirPrime HL7518 module provides the following interfaces and peripheral connectivity:

- 1x - 8-wire UART
- 1x - Active Low RESET
- 1x - USB 2.0
- 1x - Backup Battery Interface
- 2x - System Clock Out
- 1x - Active Low POWER-ON
- 1x - 1.8V/3V SIM
- 1x - JTAG Interface
- 14x - GPIOs (2 of which have multiplexes)
- 1x - Main Antenna
- 1x - RX Diversity
- 1x - VGPIIO

1.6. Connection Interface

The AirPrime HL7518 module is an LGA form factor device. All electrical and mechanical connections are made through the 146 Land Grid Array (LGA) pads on the bottom side of the PCB.

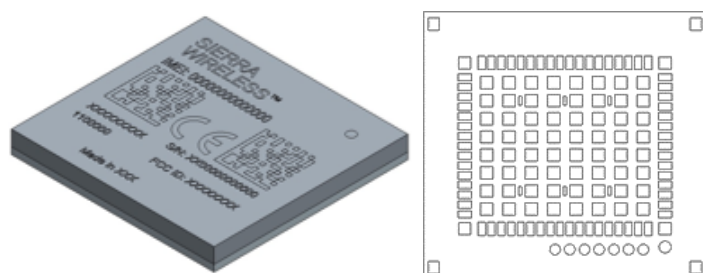

Figure 2. Mechanical Overview

The 146 pads have the following distribution:

- 66 inner signal pads, 1x0.5mm, pitch 0.8mm
- 1 reserved test point (do not connect), 1.0mm diameter
- 7 test point (JTAG), 0.8mm diameter, 1.20mm pitch
- 64 inner ground pads, 1.0x1.0mm, pitch 1.825mm/1.475mm
- 4 inner corner ground pads, 1x1mm
- 4 outer corner ground pads, 1x0.9mm

1.7. ESD

Refer to the following table for ESD Specifications.

Table 3. ESD Specifications

Category	Connection	Specification
Operational	RF ports	IEC-61000-4-2 — Level (Electrostatic Discharge Immunity Test)
Non-operational	Host connector interface	Unless otherwise specified: <ul style="list-style-type: none"> • JESD22-A114 ± 2kV Human Body Model • JESD22-A115 ± 200V Machine Model • JESD22-C101C ± 250V Charged Device Model
Signals	SIM connector	Adding ESD protection is highly recommended at the point where the USIM contacts are exposed, and for any other signals that would be subjected to ESD by the user.
	Other host signals	

1.8. Environmental and Certifications

1.8.1. Environmental Specifications

The environmental specification for both operating and storage conditions are defined in the table below.

Table 4. Environmental Specifications

Conditions	Range
Operating Class A	-30°C to +70°C
Operating Class B	-40°C to +85°C
Storage	-40°C to +85°C

Class A is defined as the operating temperature ranges that the device:

- Shall exhibit normal function during and after environmental exposure.
- Shall meet the minimum requirements of 3GPP or appropriate wireless standards.

Class B is defined as the operating temperature ranges that the device:

- Shall remain fully functional during and after environmental exposure
- Shall exhibit the ability to establish an SMS or DATA call (emergency call) at all times even when one or more environmental constraint exceeds the specified tolerance.
- Unless otherwise stated, full performance should return to normal after the excessive constraint(s) have been removed.

1.8.2. Regulatory

The AirPrime HL7518 is compliant with FCC regulations.

FCC compliance is reflected on the AirPrime HL7518 label.

Table 5. Regulation Compliance

Document	Version	Title
GCF-CC	v3.51.1 or later	GCF Conformance Certification Criteria
FCC Part 27	NA	Miscellaneous wireless communication services

1.8.3. RoHS Directive Compliance

AirPrime HL7518 modules are compliant with RoHS Directive 2011/65/EU, including directive 2015/863 amending annex II, which sets limits for the use of certain restricted hazardous substances. This directive states that electrical and electronic equipment put on the market does not contain lead, mercury, cadmium, hexavalent chromium, polybrominated biphenyls (PBB), polybrominated diphenyl ethers (PBDE), Bis (2-ethylhexyl) phthalate (DEHP), Butyl benzyl phthalate (BBP), Dibutyl phthalate (DBP) or Diisobutyl phthalate (DIBP) above threshold limits.

1.8.4. Disposing of the Product

This electronic product is subject to the EU Directive 2012/19/EU for Waste Electrical and Electronic Equipment (WEEE). As such, this product must not be disposed of at a municipal waste collection point. Please refer to local regulations for directions on how to dispose of this product in an environmental friendly manner.



1.9. References

- [1] AirPrime HL Series Customer Process Guidelines
Reference Number: 4114330
- [2] AirPrime HL7518 and HL7548 AT Commands Interface Guide
Reference Number: 4116303
- [3] AirPrime HL Series Development Kit User Guide
Reference Number: 4114877

2. Pad Definition

AirPrime HL7518 pads are divided into 2 functional categories.

- **Core functions and associated pads** cover all the mandatory features for M2M connectivity and will be available by default across all CF³ family of modules. These Core functions are always available and always at the same physical pad locations. A customer platform using only these functions and associated pads is guaranteed to be forward and/or backward compatible with the next generation of CF³ modules.
- **Extension functions and associated pads** bring additional capabilities to the customer. Whenever an Extension function is available on a module, it is always at the same pad location.

Other pads marked as “not connected” or “reserved” should not be used.

Table 6. Pad Definition

Pad #	Signal Name	Function	I/O	Active Low/High	Reset State*	Power Supply Domain	Recommendation for Unused Pads	Type
1	GPIO1	General purpose input/output	I/O		T	1.8V	Left Open	Extension
2	UART1_RI / TRACE_DATA3	UART1 Ring indicator / Trace data 3	O		L	1.8V	Connect to test point	Core
3	UART1_RTS	UART1 Request to send	I	L	T/PU	1.8V	Connect to test point	Core
4	UART1_CTS	UART1 Clear to send	O	L	T/PU	1.8V	Connect to test point	Core
5	UART1_TX	UART1 Transmit data	I		T/PD	1.8V	Connect to test point	Core
6	UART1_RX	UART1 Receive data	O		T/PU	1.8V	Connect to test point	Core
7	UART1_DTR	UART1 Data terminal ready	I	L	T/PD	1.8V	Connect to test point	Core
8	UART1_DCD / TRACE_DATA1	UART1 Data carrier detect / Trace data 1	O	L	L	1.8V	Connect to test point	Core
9	UART1_DSR / TRACE_DATA0	UART1 Data set ready / Trace data 0	O	L	H	1.8V	Connect to test point	Core

Pad #	Signal Name	Function	I/O	Active Low/High	Reset State*	Power Supply Domain	Recommendation for Unused Pads	Type
10	GPIO2 / TRACE_DATA2	General purpose input/output / Trace data 2	I/O		L	1.8V	Connect to test point	Core
11	RESET_IN_N	Input reset signal	I	L	N/A	1.8V	Left Open	Core
12	USB_D-	USB Data Negative (Low / Full Speed)	I/O		T	3.3V	Connect to test point	Extension
		USB Data Negative (High Speed)				0.38V		
13	USB_D+	USB Data Positive (Low / Full Speed)	I/O		T	3.3V	Connect to test point	Extension
		USB Data Positive (High Speed)				0.38V		
14	NC	Not Connected			N/A			Not connected
15	NC	Not Connected			N/A			Not connected
16	USB_VBUS	USB VBUS	I		N/A	3.3V – 5.5V	Connect to test point	Extension
17	NC	Not Connected (Reserved for future use)					Left Open	Not connected
18	NC	Not Connected (Reserved for future use)					Left Open	Not connected
19	NC	Not Connected (Reserved for future use)					Left Open	Not connected
20	NC	Not Connected (Reserved for future use)					Left Open	Not connected
21	BAT_RTC	Power supply for RTC backup	I/O		N/A	1.8V	Left Open	Extension
22	26M_CLKOUT	26MHz System Clock Output	O		T/PD	1.8V	Left Open	Extension
23	32K_CLKOUT	32.768kHz System Clock Output	O		T/PD	1.8V	Left Open	Extension
24	NC	Not Connected (Reserved for future use)					Left Open	Not connected
25	NC	Not Connected (Reserved for future use)					Left Open	Not connected
26	UIM1_VCC	1.8V/3V SIM1 Power supply	O		N/A	1.8V/3V	Mandatory connection	Core
27	UIM1_CLK	1.8V/3V SIM1 Clock	O		L	1.8V/3V	Mandatory connection	Core
28	UIM1_DATA	1.8V/3V SIM1 Data	I/O		L	1.8V/3V	Mandatory connection	Core
29	UIM1_RESET	1.8V/3V SIM1 Reset	O	L	L	1.8V/3V	Mandatory connection	Core
30	GND	Ground	0V		N/A	0V	Mandatory connection	Extension
31	RF_DIV	RF Input - Diversity			N/A		Mandatory connection	Extension

Pad #	Signal Name	Function	I/O	Active Low/High	Reset State*	Power Supply Domain	Recommendation for Unused Pads	Type
32	GND	Ground	0V		N/A	0V	Mandatory connection	Extension
33	PCM_OUT*	PCM data out	O		T/PD	1.8V	Left Open	Extension
34	PCM_IN*	PCM data in	I		T/PD	1.8V	Left Open	Extension
35	PCM_SYNC*	PCM sync out	I/O		T/PD	1.8V	Left Open	Extension
36	PCM_CLK*	PCM clock	I/O		T/PD	1.8V	Left Open	Extension
37	GND	Ground	0V		N/A	0V	Mandatory connection	Core
38	NC	Not Connected (Reserved for future use)					Left Open	Not connected
39	GND	Ground	0V		N/A	0V	Mandatory connection	Core
40	GPIO7	General purpose input/output	I/O		T/PD	1.8V	Left Open	Core
41	GPIO8 / TRACE_CLK	General purpose input/output / Trace clock	I/O		L	1.8V	Connect to test point	Core
42	NC	Not Connected (Reserved for future use)					Left Open	Not connected
43	NC	Not Connected (Reserved for future use)					Left Open	Not connected
44	GPIO13	General purpose input/output	O		T/PU	1.8V	Left Open	Extension
45	VGPIO	GPIO voltage output	O		N/A	1.8V	Left Open	Core
46	GPIO6	General purpose input/output	I/O		T/PD	1.8V	Left Open	Core
47	NC	Not Connected (Reserved for future use)					Left Open	Not connected
48	GND	Ground	0V		N/A	0V	Mandatory connection	Core
49	RF_MAIN	RF Input/output			N/A		Mandatory connection	Core
50	GND	Ground	0V		N/A	0V	Mandatory connection	Core
51	GPIO14	General purpose input/output	I		T/PU	1.8V	Left Open	Extension
52	GPIO10	General purpose input/output	I/O		T/PD	1.8V	Left Open	Extension
53	GPIO11	General purpose input/output	I/O		T/PD	1.8V	Left Open	Extension
54	GPIO15	General purpose input/output	I/O		T/PU	1.8V	Left Open	Extension

Pad #	Signal Name	Function	I/O	Active Low/High	Reset State*	Power Supply Domain	Recommendation for Unused Pads	Type
55	NC	Not Connected (Reserved for future use)					Left Open	Not connected
56	NC	Not Connected (Reserved for future use)					Left Open	Not connected
57	NC	Not Connected (Reserved for future use)					Left Open	Not connected
58	GPIO12	General purpose input/output	I/O		L	1.8V	Left Open	Extension
59	PWR_ON_N	Active Low Power On control signal	I	L	N/A	1.8V	Mandatory connection	Core
60	NC	Not Connected (Reserved for future use)					Left Open	Not connected
61	VBATT_PA	Power supply (refer to section 3.1 Power Supply for more information)	I		N/A	3.2V (min) 3.7V (typ) 4.5V (max)	Mandatory connection	Core
62	VBATT_PA	Power supply (refer to section 3.1 Power Supply for more information)	I		N/A	3.2V (min) 3.7V (typ) 4.5V (max)	Mandatory connection	Core
63	VBATT	Power supply	I		N/A	3.2V (min) 3.7V (typ) 4.5V (max)	Mandatory connection	Core
64	UIM1_DET / GPIO3	UIM1 Detection / General purpose input/output	I/O	H	T/PD	1.8V	Left Open	Core
65	GPIO4	General purpose input/output	I/O	H	T/PD	1.8V	Left Open	Extension
66	GPIO5	General purpose input/output	I/O		T	1.8V	Left Open	Extension
67-70	GND	Ground	GND		N/A	0V		Core
71 - 166	<i>Note: These pads are not available on the AirPrime HL7518 module.</i>							
167 - 234	GND	Ground	GND		N/A	0V		Core
236	JTAG_RESET	JTAG RESET	I	L	N/A	1.8V	Left Open	Extension
237	JTAG_TCK	JTAG Test Clock	I		PD	1.8V	Left Open	Extension
238	JTAG_TDO	JTAG Test Data Output	O		T	1.8V	Left Open	Extension
239	JTAG_TMS	JTAG Test Mode Select	I		PU	1.8V	Left Open	Extension

Pad #	Signal Name	Function	I/O	Active Low/High	Reset State*	Power Supply Domain	Recommendation for Unused Pads	Type
240	JTAG_TRST	JTAG Test Reset	I	L	PD	1.8V	Left Open	Extension
241	JTAG_TDI	JTAG Test Data Input	I		PU	1.8V	Left Open	Extension
242	JTAG_RTCK	JTAG Returned Test Clock	O		PD	1.8V	Left Open	Extension

* PU = Pull up, PD = Pull down, H = High, L = Low, T = High impedance, N/A = Not applicable.

2.1. Pad Configuration (Top View, Through Module)

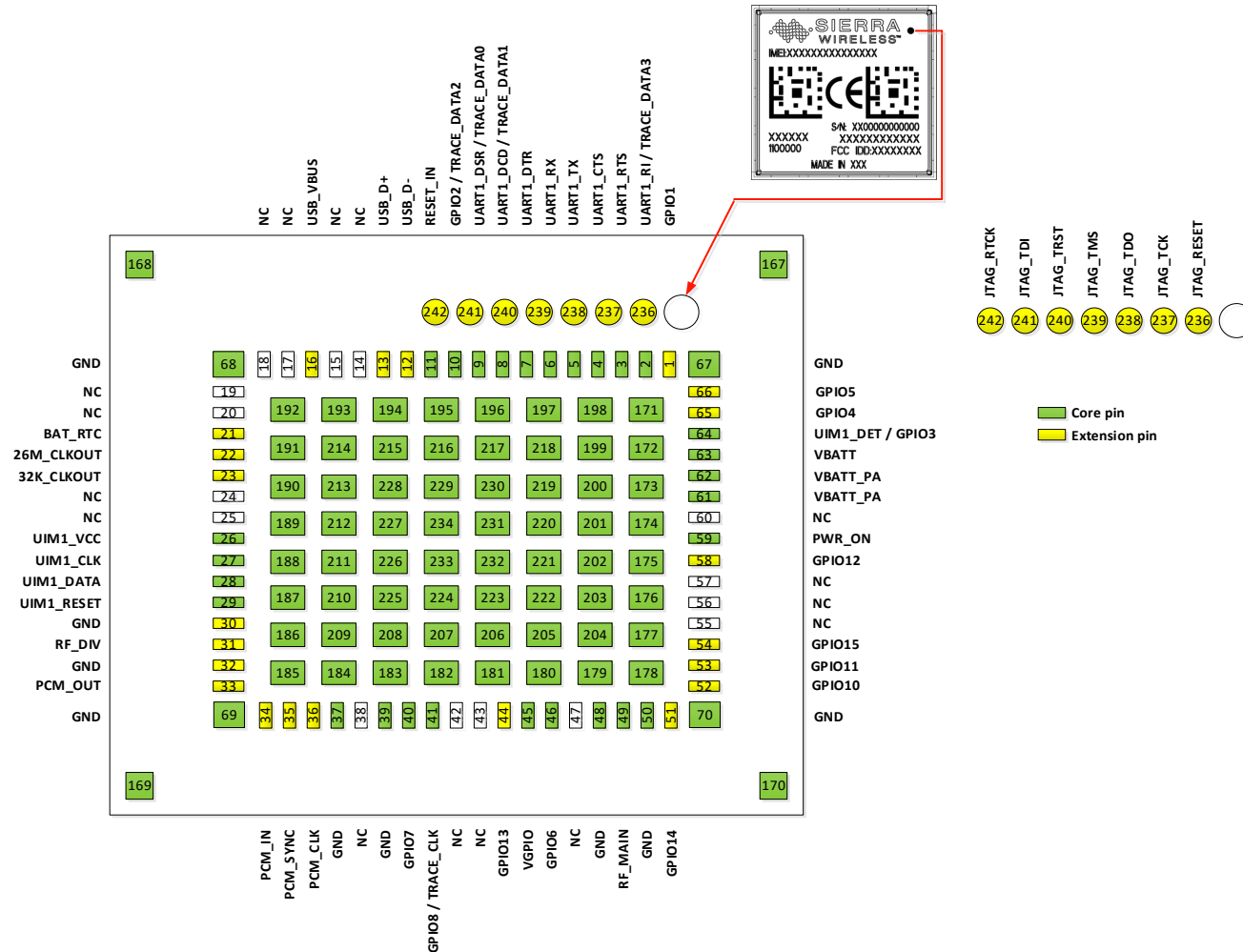

Figure 3. Pad Configuration

3. Detailed Interface Specifications

Note: If not specified, all electrical values are given for VBATT=3.7V and an operating temperature of 25°C.

VBATT and VBATT_PA must be tied externally to the same power supply.

3.1. Power Supply

The AirPrime HL7518 module is supplied through the VBATT signal with the following characteristics.

Table 7. Power Supply

Supply	Minimum	Typical	Maximum
VBATT voltage (V)	3.2*	3.7	4.5
VBATT_PA voltage (V) Full Specification	3.2*	3.7	4.5

* This value must be guaranteed during the burst.

Note: Load capacitance for VBATT is around $32\mu\text{F} \pm 20\%$ embedded inside the module.
Load capacitance for VBATT_PA is around $10\mu\text{F} \pm 20\%$ embedded inside the module.

3.2. Current Consumption

The following table lists the current consumption of the AirPrime HL7518 at different conditions.

Note: Typical values are defined for VBATT/VBATT_PA at 3.7V and 25°C, for 50Ω impedance at all RF ports. Maximum values are provided for VSWR 3:1 with worst conditions among supported ranges of voltages and temperature.

Table 8. Current Consumption

Parameter		Minimum	Typical	Maximum	Unit
Off mode		95.0	110	202.0	μA
Sleep mode – LTE DRX = 1.28s USB = suspended	Band 4	1.2	1.4	6.2	mA
	Band 13	1.2	1.4	6.2	mA
LTE in communication mode (TX Max)	Band 4	510.0	610.0	945.0	mA
	Band 13	460.0	548.0	720.0	mA

3.3. VGPIO

The VGPIO output can be used to:

- Pull-up signals such as I/Os
- Supply the digital transistors driving LEDs

The VGPIO output is available when the AirPrime HL7518 module is switched ON.

Table 9. VGPIO Electrical Characteristics

Parameter	Minimum	Typical	Maximum	Remarks
Voltage level (V)	1.7	1.8	1.9	Both active mode and sleep mode
Current capability Active Mode (mA)	-	-	50	Power management support up to 50mA output in Active mode
Current capability Sleep Mode (mA)	-	-	3	Power management support up to 3mA output in Sleep mode
Rise Time (ms)	-	-	1.5	Start-Up time from 0V

3.4. BAT_RTC

The AirPrime HL7518 module provides an input/output to connect a Real Time Clock power supply.

This pad is used as a back-up power supply for the internal Real Time Clock. The RTC is supported when VBATT is available but a back-up power supply is needed to save date and hour when VBATT is switched off.

If VBATT is available, the back-up battery can be charged by the internal 1.8V power supply regulator.

Table 10. BAT_RTC Electrical Characteristics

Parameter	Minimum	Typical	Maximum	Unit
Input voltage	-	1.8	-	V
Input current consumption	-	2.5	-	μA
Output voltage	-5%	1.8	+5%	V
Max charging current (@VBATT=3.7V)	-	25	-	mA

3.5. SIM Interface

The AirPrime HL7518 has one physical SIM interface, UIM1.

It allows control of a 1.8V/3V SIM and is fully compliant with GSM 11.11 recommendations concerning SIM functions.

The five signals used by UIM1 are as follows:

- UIM1_VCC: power supply
- UIM1_CLK: clock
- UIM1_DATA: I/O port
- UIM1_RESET: reset
- UIM1_DET: SIM detection

Table 11. UIM1 Pad Description

Pad #	Signal Name	Description	Multiplex
26	UIM1_VCC	1.8V/3V SIM1 Power supply	
27	UIM1_CLK	1.8V/3V SIM1 Clock	
28	UIM1_DATA	1.8V/3V SIM1 Data	
29	UIM1_RESET	1.8V/3V SIM1 Reset	
64	UIM1_DET	UIM1 Detection	GPIO3

Table 12. Electrical Characteristics of UIM1

Parameter	Minimum	Typical	Maximum	Remarks
UIM1 Interface Voltage (V) (VCC, CLK, IO, RST)	-	2.9	-	The appropriate output voltage is auto detected and selected by software.
	-	1.80	-	
UIM1 Detect	-	1.80	-	High active
UIM1_VCC Current (mA)	-	-	10	Max output current in sleep mode = 3 mA
UIM1_VCC Line Regulation (mV/V)	-	-	50	At Iout_Max
UIM1_VCC Power-up Setting Time (µs) from power down	-	10	-	

3.5.1. UIM1_DET

UIM1_DET is used to detect and notify the application about the insertion and removal of a SIM device in the SIM socket connected to the SIM interface. When a SIM is inserted, the state of UIM1_DET transitions from logic 0 to logic 1. Inversely, when a SIM is removed, the state of UIM1_DET transitions from logic 1 to logic 0.

3.6. USB

The AirPrime HL7518 has one USB interface.

Table 13. USB Pad Description

Pad Number	Signal Name	I/O	Function
12	USB_D-	I/O	USB Data Negative
13	USB_D+	I/O	USB Data Positive
16	USB_VBUS	I	USB VBUS

Note: When a USB supply is not available, connect USB_VBUS to VBATT to supply the USB interface. USB_VBUS will have a voltage range of 3.3V to 4.5V when connected to VBATT.

3.7. Electrical Information for Digital I/O

The table below enumerates the electrical characteristics of the following digital interfaces:

- UART
- GPIOs
- JTAG
- RESET

Table 14. Digital I/O Electrical Characteristics

Parameter	Symbol	Minimum	Maximum
Input Current-High (μ A)	I_{IH}	-	-240
Input Current-Low (μ A)	I_{IL}	-	240
DC Output Current-High (mA)	I_{OH}	-	6
DC Output Current-Low (mA)	I_{OL}	-6	-
Input Voltage-High (V)	V_{IH}	1.33	1.90
Input Voltage-Low (V)	V_{IL}	-0.20	0.34
Output Voltage-High (V)	V_{OH}	1.45	-
Output Voltage-Low (V)	V_{OL}	-	0.35

3.8. General Purpose Input/Output (GPIO)

The AirPrime HL7518 modules provide 14 GPIOs, 2 of which have multiplexes.

Table 15. GPIO Pad Description

Pad #	Signal Name	Multiplex	I/O	Power Supply Domain
1	GPIO1		I/O	1.8V
10	GPIO2	TRACE_DATA2	I/O	1.8V
40	GPIO7		I/O	1.8V
41	GPIO8	TRACE_CLK	I/O	1.8V
44	GPIO13		I/O	1.8V
46	GPIO6		I/O	1.8V
51	GPIO14		I/O	1.8V
52	GPIO10		I/O	1.8V
53	GPIO11		I/O	1.8V
54	GPIO15		I/O	1.8V
58	GPIO12		I/O	1.8V
64	GPIO3		I/O	1.8V
65	GPIO4		I/O	1.8V
66	GPIO5		I/O	1.8V

3.9. Main Serial Link (UART1)

The main serial link (UART1) is used for communication between the AirPrime HL7518 module and a PC or host processor. It consists of a flexible 8-wire serial interface that complies with RS-232 interface.

The supported baud rates of the UART1 are 300, 1200, 2400, 4800, 9600, 19200, 38400, 57600, 115200, 230400, 460800, 500000, 750000, 921600, 1843200, 3000000 and 3250000 bit/s.

The signals used by UART1 are as follows:

- TX data (UART1_TX)
- RX data (UART1_RX)
- Request To Send (UART1_RTS)
- Clear To Send (UART1_CTS)
- Data Terminal Ready (UART1_DTR)
- Data Set Ready (UART1_DSR)
- Data Carrier Detect (UART1_DCD)
- Ring Indicator (UART1_RI)

Note: Signal names are according to PC view.

UART1 pad description is summarized in the table below.

Table 16. UART1 Pad Description

Pad #	Signal Name*	I/O*	Description
2	UART1_RI	O	Signal incoming calls (data only), SMS, etc.
3	UART1_RTS	I	Wakes the module up
4	UART1_CTS	O	AirPrime HL7518 is ready to receive AT commands
5	UART1_TX	I	Transmit data
6	UART1_RX	O	Receive data
7	UART1_DTR	I (active low)	Prevents the AirPrime HL7518 from entering sleep mode, switches between data mode and command mode, and wakes the module up.
8	UART1_DCD	O	Signal data connection in progress
9	UART1_DSR	O	Signal UART interface is ON

* According to PC view.

Note: UART1 input signal pins (UART1_RTS, UART1_TX and UART1_DTR) are internally pulled up by an 8kΩ resistor when the module is ON.

3.10. POWER-ON Signal (PWR_ON_N)

A low-level signal must be provided to switch the AirPrime HL7518 module ON.

It is internally connected to the permanent 1.8V supply regulator inside the HL7518 via a pull-up resistor. Once VBAT is supplied to the HL7518 module, this 1.8V supply regulator will be enabled and so the PWR_ON_N signal is by default at high level.

The PWR_ON_N signal's characteristics are listed in the table below.

Table 17. PWR_ON_N Electrical Characteristics

Parameter	Minimum	Typical	Maximum
Input Voltage-Low (V)		-	0.51
Input Voltage-High (V)	1.33	-	2.2
Power-up period (ms) from PWR_ON_N falling edge	2000	-	-
PWR_ON_N assertion time (ms)	25		

Note: As PWR_ON_N is internally pulled up with 100kΩ, an open collector or open drain transistor must be used for ignition.

VGPIO is an output from the module that can be used to check if the module is active.

- When VGPIO = 0V, the module is OFF
- When VGPIO = 1.8V, the module is ON (it can be in idle, communication or sleep mode)

Note: PWR_ON_N signal cannot be used to power the module off. To power the module off, use AT command **AT+CPWROFF**.

3.11. Reset Signal (RESET_IN_N)

To reset the module, a low-level pulse must be sent on the RESET_IN_N pad for 20ms. This action will immediately restart the AirPrime HL7518 module with the PWR_ON_N signal at low level. (If the PWR_ON_N signal is at high level, the module will be powered off.) As RESET_IN_N is internally pulled up, an open collector or open drain transistor should be used to control this signal.

The RESET_IN_N signal will reset the registers of the CPU and reset the RAM memory as well, for the next power on.

Note: As RESET_IN_N is referenced to the VRTC (200kΩ pull-up resistor to VRTC 1.8V) an open collector or open drain transistor has to be used to control this signal.

Table 18. RESET_IN_N Electrical Characteristics

Parameter	Minimum	Typical	Maximum
Input Voltage-Low (V)		-	0.51
Input Voltage-High (V)	1.33	-	2.2
Reset assertion time (ms)	20	-	-
Power-up period (ms) from RESET_IN_N falling edge*	2000	-	-

* With the PWR_ON_N Signal at low level

3.12. Clock Interface

The AirPrime HL7518 modules support two digital clock interfaces.

The following table describes the pad description of the clock out interfaces.

Table 19. Clock Interface Pad Description

Pad Number	Signal Name	I/O	I/O Type	Description
22	26M_CLKOUT	O	1.8V	26MHz Digital Clock output
23	32K_CLKOUT	O	1.8V	32.768kHz Digital Clock output

Enabling or disabling the clock out feature can be done using AT commands. For more information about AT commands, refer to document [2] AirPrime HL7518 and HL7548 AT Commands Interface Guide.

3.13. Debug Interfaces

The AirPrime HL7518 module provides 3 interfaces for a powerful debug system.

3.13.1. USB

The USB interface is the primary debug interface for customers to collect traces.

Table 20. USB Pad Description

Pad Number	Signal Name	I/O	Function
12	USB_D-	I/O	USB Data Negative
13	USB_D+	I/O	USB Data Positive
16	USB_VBUS	I	USB VBUS

Note: It is strongly recommended to reserve test points to collect traces in case USB is not used.

3.13.2. JTAG

Note: This interface is reserved for Sierra Wireless' internal debug use (for customer support).

The JTAG interface provides debug access to the core of the HL7518. These JTAG signals are accessible through solder-able test points.

Table 21. JTAG Pad Description

Pad Number	Signal Name	Function
236	JTAG_RESET	JTAG RESET
237	JTAG_TCK	JTAG Test Clock
238	JTAG_TDO	JTAG Test Data Output
239	JTAG_TMS	JTAG Test Mode Select
240	JTAG_TRST	JTAG Test Reset
241	JTAG_TDI	JTAG Test Data Input
242	JTAG_RTCK	JTAG Returned Test Clock

Note: It is recommended to provide access through Test Points to this interface (for Failure Analysis debugging). All signals listed in the table above should be outputs on the customer board to allow JTAG debugging.

3.13.3. Trace Debug

In addition to the USB and JTAG interfaces, the AirPrime HL7518 module provides a Trace Debug interface, providing real-time instruction and data trace of the modem core.

Table 22. Trace Debug Pad Description

Pad Number	Signal Name	Function
2	TRACE_DATA3	Trace data 3
8	TRACE_DATA1	Trace data 1
9	TRACE_DATA0	Trace data 0
10	TRACE_DATA2	Trace data 2
41	TRACE_CLK	Trace clock

Note: *It is strongly recommended to provide access to this interface through Test Points for Sierra Wireless' internal debug use (for customer support). Access to the USB debug interface described in section 3.13.1 USB should also always be provided when using this interface.*

3.14. RF Interface

The RF interface of the HL7518 module allows the transmission of RF signals. This interface has a 50Ω nominal impedance.

Contact Sierra Wireless technical support for assistance in integrating the AirPrime HL7518 on applications with embedded antennas.

3.14.1. RF Connection

A 50Ω stripline can be used to connect to standard RF connectors such as SMA, UFL, etc. for antenna connection.

Table 23. RF Main Connection

Pad Number	RF Signal	Impedance	VSWR Rx (max)	VSWR Tx (max)
49	RF_MAIN	50Ω	1.5:1	1.5:1

Table 24. RF Diversity Connection

Pad Number	RF Signal	Impedance	VSWR Rx (max)	VSWR Tx (max)
31	RF_DIV	50Ω	1.5:1	-

3.14.2. RF Performances

RF performances are compliant with 3GPP recommendation TS 36.101.

Table 25. Conducted RX Sensitivity (dBm)

Frequency Band		Primary (Typical)	Secondary (Typical)	SIMO (Typical)
LTE B4	Full RB; BW: 20 MHz*	-95	-95	-99
LTE B13	Full RB; BW: 10 MHz*	-98	-99	-102

* Sensitivity values scale with bandwidth: $x_MHz_Sensitivity = 10\ MHz_Sensitivity - 10 \cdot \log(10\ MHz/x_MHz)$



4. Mechanical Drawings

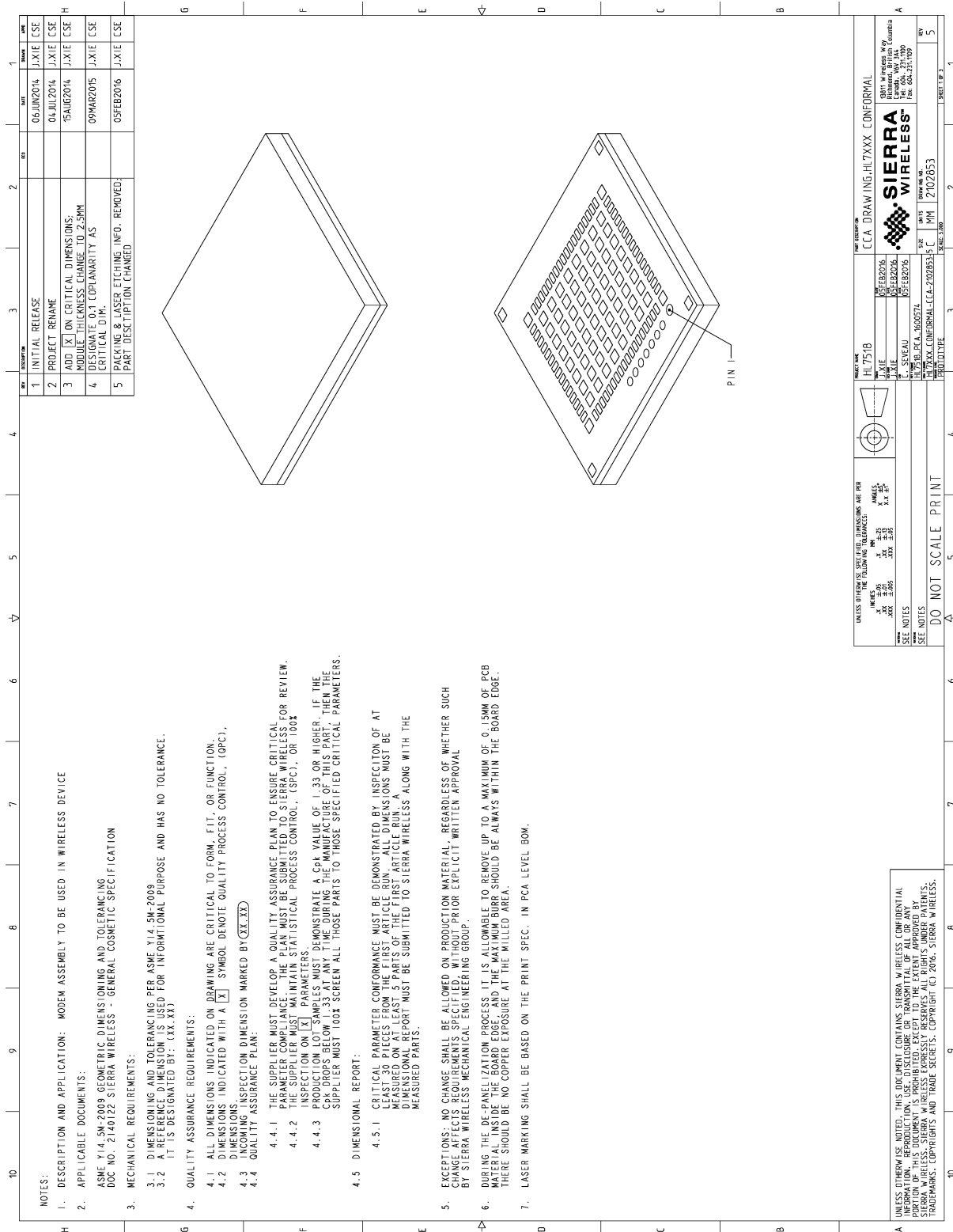

Figure 4. Mechanical Drawing

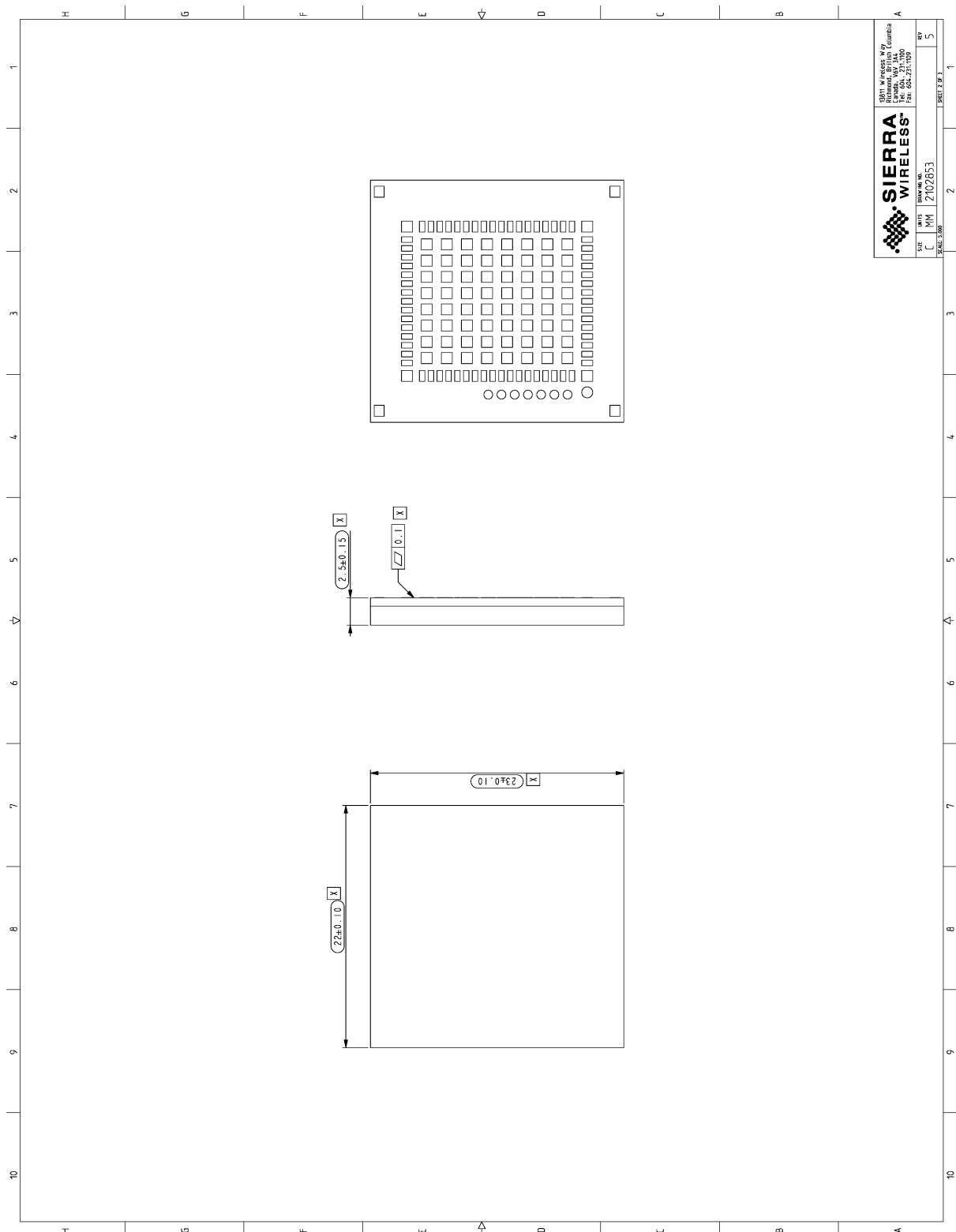
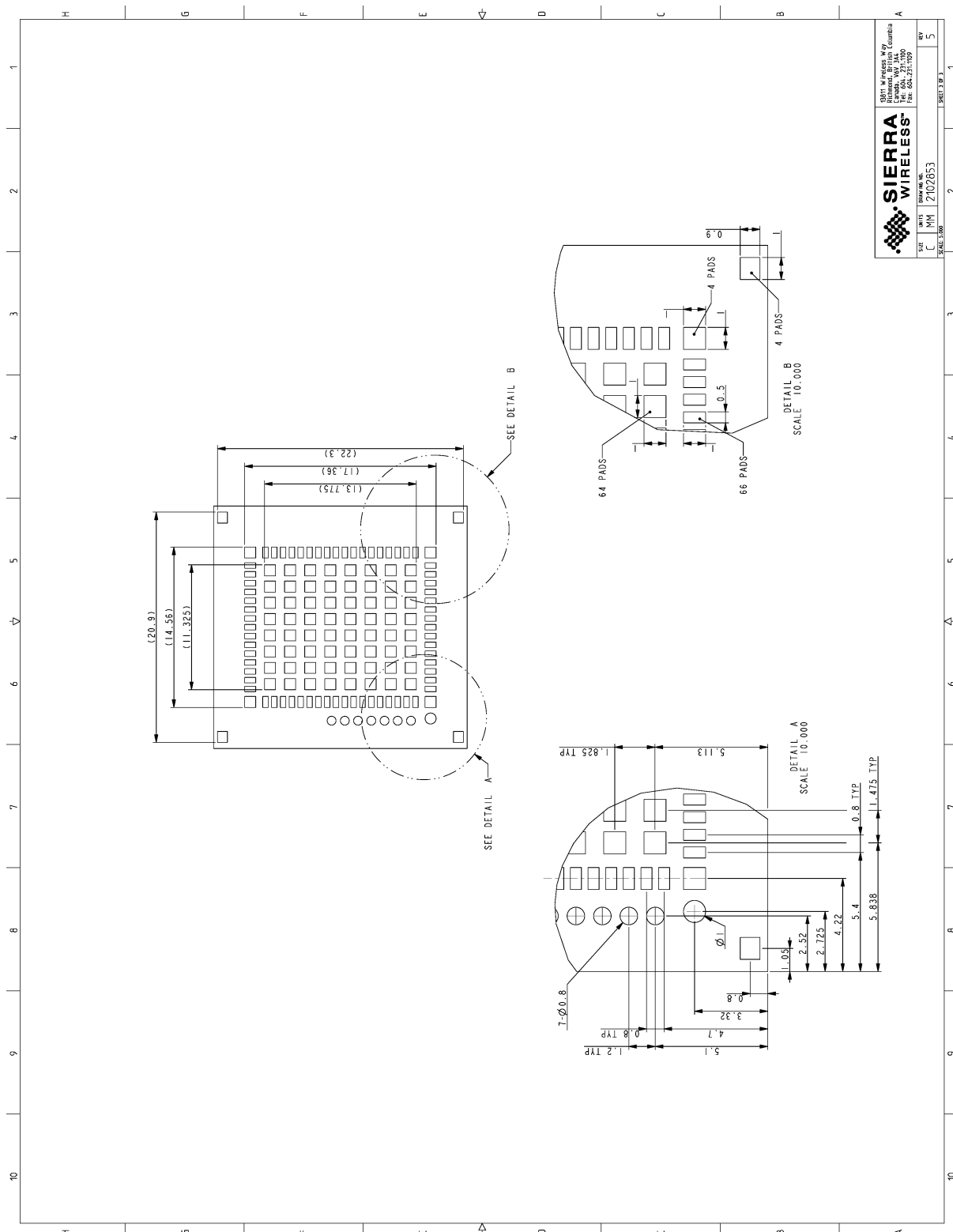

Figure 5. Dimensions Drawing



>> 5. Design Guidelines

5.1. Power-Up Sequence

Apply a low-level logic to the PWR_ON_N pad (pad 59); within approximately 25ms, VGPIO will appear to be at 1.8V. Either UART1 or the USB interface could be used to send AT commands. The AT command interface is available in about 7 seconds after PWR_ON_N for either UART or USB.

When using UART, the AT command interface is available after the transition of UART1_CTS from high to low level.

When using a USB connection, the HL7518 will start communicating with the host after USB enumeration. The time when AT commands can be sent will depend on the initialization time on the USB host.

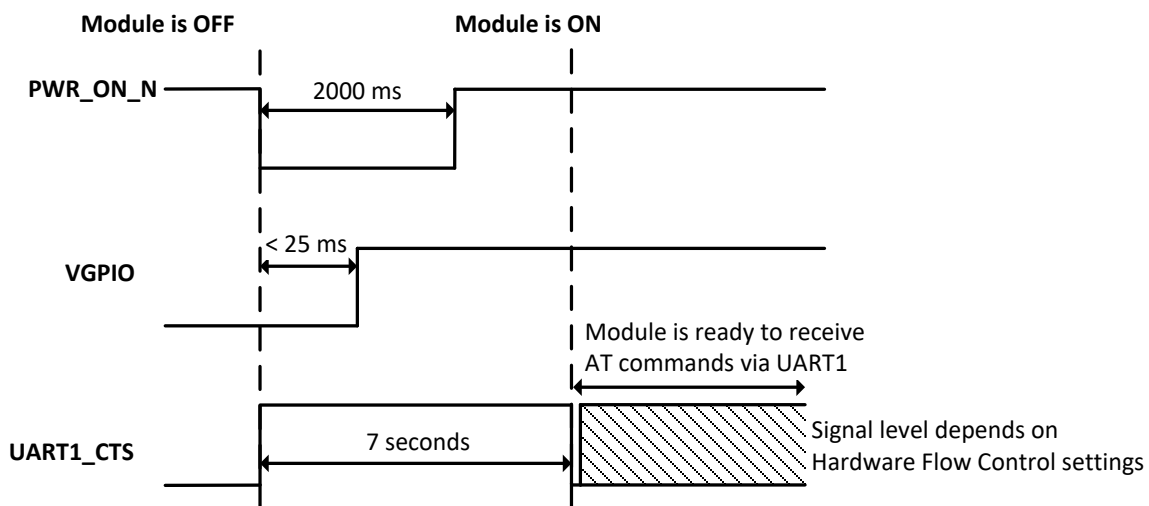

Figure 7. PWR_ON_N Sequence with VGPIO Information

Note: As PWR_ON_N is internally pulled up with 100kΩ, an open collector or open drain transistor must be used for ignition.

The PWR_ON_N pad has the minimum assertion time requirement of 25ms, with LOW active. Once the valid power on trigger is detected, the PWR_ON_N pad status can be left open.

The maximum inrush current is 1.3 A and lasts less than 1.5 ms.

5.2. Module Switch-Off

AT command `AT+CPWROFF` enables the user to properly switch the AirPrime HL7518 module off.

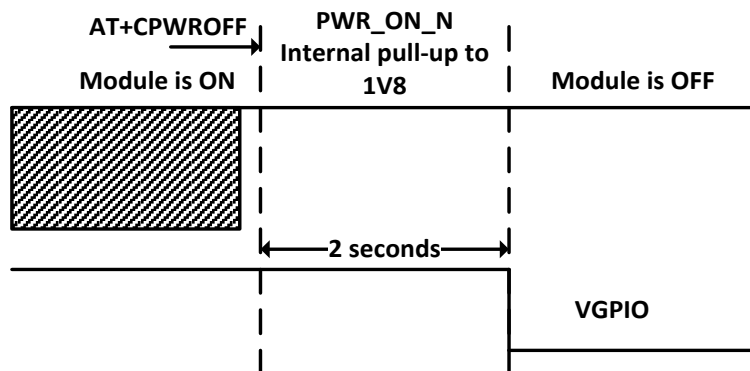

Figure 8. Power OFF Sequence for PWR_ON_N, VGPIO

Note: PWR_ON_N is internally pulled up by 100kΩ to 1.8V.

5.3. Emergency Power OFF

If required, the module can be switched off by controlling the RESET_IN_N pad (pad 11). This must only be used in emergency situations if the system freezes (not responding to AT commands).

To perform an emergency power off, a low-level pulse must be sent on the RESET_IN_N pad for 20ms while the PWR_ON_N signal is inactive (high level). This action will immediately shut the HL7518 module down and the registers of the CPU and RAM memory will be reset for the next power on.

5.4. Sleep Mode Management

5.4.1. Using UART1

AT command `AT+KSLEEP` enables sleep mode configuration.

AT+KSLEEP=0:

- The module is active when DTR signal is active (low electrical level).
- When DTR is deactivated (high electrical level), module enters sleep mode after a while.
- On DTR activation (low electrical level), the module wakes up.

AT+KSLEEP=1:

- The module determines when it enters sleep mode (when no more tasks are running).
- “0x00” character on the serial link wakes the module up.

AT+KSLEEP=2: The module never enters sleep mode.

5.4.2. Using USB

Use `AT+KSLEEP=1` to allow the module to automatically enter sleep mode while the USB interface is in use.

5.5. Power Supply Design

The AirPrime HL7518 module should not be supplied with voltage over 4.5V even temporarily or however briefly.

If the system's main board power supply unit is unstable or if the system's main board is supplied with over 4.5V, even in the case of transient voltage presence on the circuit, the module's power amplifier may be severely damaged.

To avoid such issues, add a voltage limiter to the module's power supply lines so that VBATT and VBATT_PA signal pads will never receive a voltage surge over 4.5V. The voltage limiter can be as simple as a Zener diode with decoupling capacitors as shown in the diagram below.

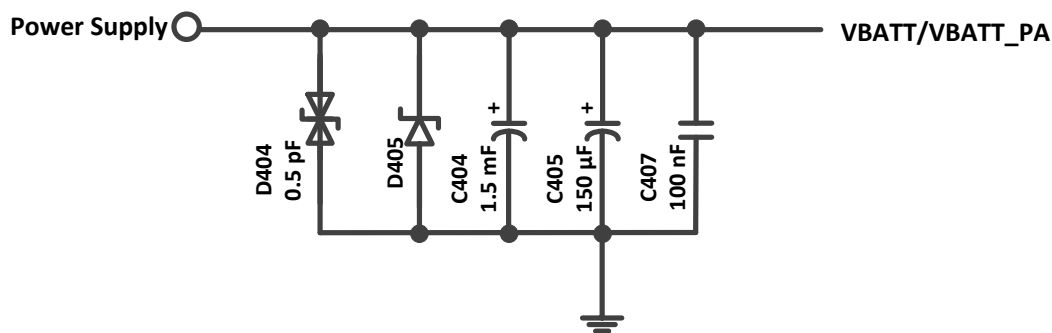

Figure 9. Voltage Limiter Example

5.6. Power Cycle

In addition to Sierra Wireless' reliable recovery mechanisms, it is highly recommended that the ability for a power cycle to reboot the module be included in the design in case the module becomes blocked and stops responding to reset commands.

5.7. ESD Guidelines for SIM Card

Decoupling capacitors must be added according to the drawings below as close as possible to the SIM card connectors on UIM1_CLK, UIM1_RST, UIM1_VCC, UIM1_DATA and UIM1_DET signals to avoid EMC issues and to comply with the requirements of ETSI and 3GPP standards covering the SIM electrical interface.

A typical schematic including SIM detection is provided below.

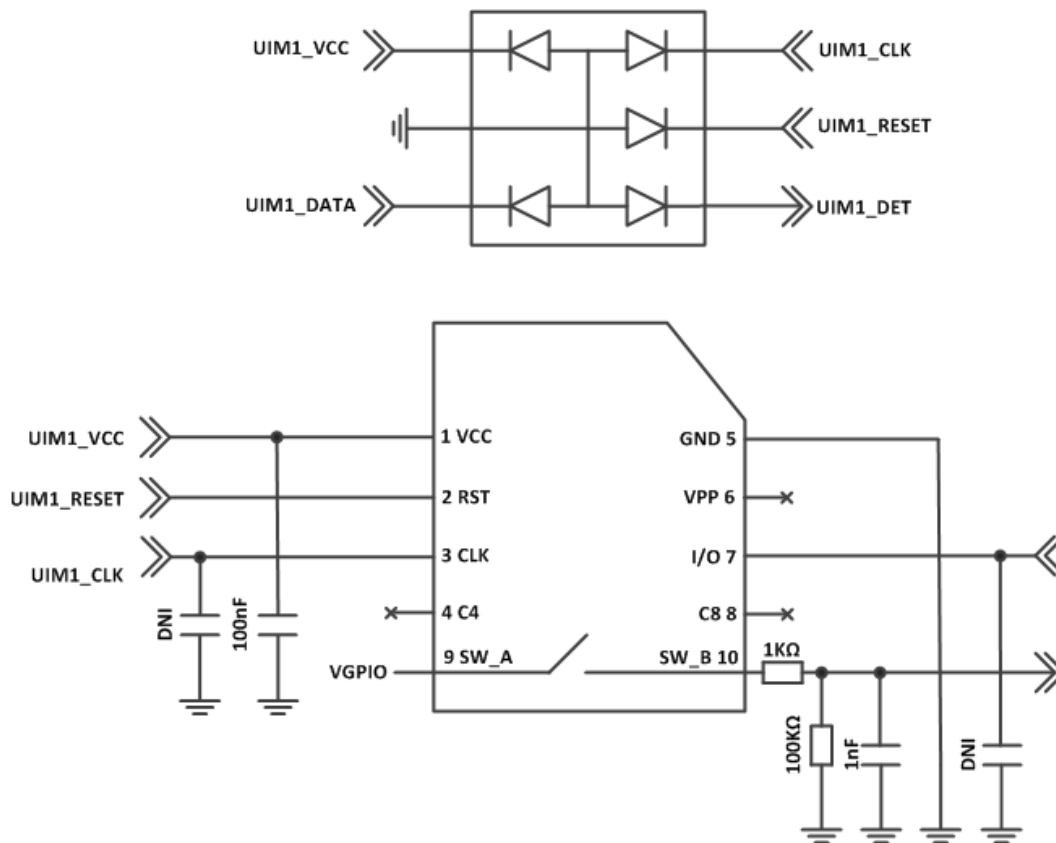

Figure 10. EMC and ESD Components Close to the SIM

5.8. ESD Guidelines for USB

When the USB interface is externally accessible, it is required to have ESD protection on the USB_VBUS, USB_D+ and USB_D- signals.

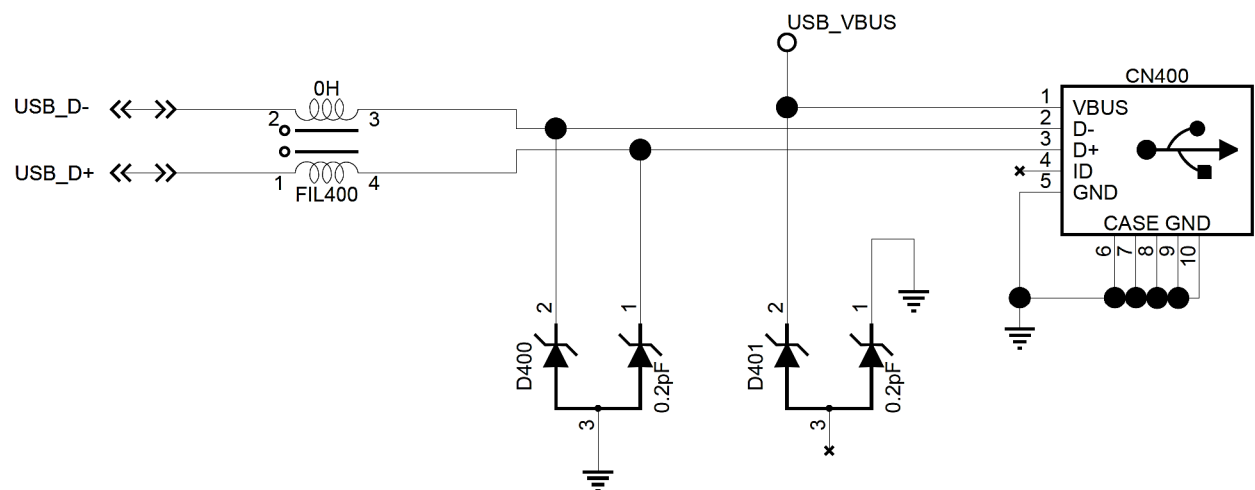

Figure 11. ESD Protection for USB

Note: It is not recommended to have an ESD diode with feedback path from USB_VBUS to either USB_D+ or USB_D-.

Sierra Wireless recommends using a 90Ω DLP0NSN900HL2L EMC filter and an RCLAMP0503N or ESD5V3U2U-03LRH ESD diode.

>> 6. Reliability Specification

AirPrime HL7518 modules are tested against the Sierra Wireless Industrial Reliability Specification defined below.

6.1. Reliability Compliance

The AirPrime HL7518 module connected on a development kit board application is compliant with the following requirements.

Table 26. Standards Conformity

Abbreviation	Definition
IEC	International Electro technical Commission
ISO	International Organization for Standardization

6.2. Reliability Prediction Model

6.2.1. Life Stress Test

The following tests the AirPrime HL7518 module's product performance.

Table 27. Life Stress Test

Designation	Condition
Performance Test PT3T & PTRT 	Standard: N/A
	Special conditions: <ul style="list-style-type: none">• Temperature:<ul style="list-style-type: none">▪ Class A: -30°C to +70°C▪ Class B: -40°C to +85°C• Rate of temperature change: $\pm 3^\circ\text{C}/\text{min}$• Recovery time: 3 hours
	Operating conditions: Powered
	Duration: 14 days

6.2.2. Environmental Resistance Stress Tests

The following tests the AirPrime HL7518 module’s resistance to extreme temperature.

Table 28. Environmental Resistance Stress Tests

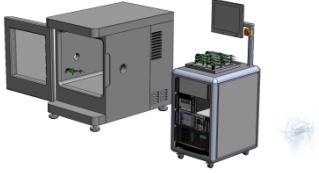
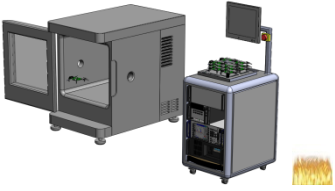
Designation	Condition
Cold Test Active COTA 	Standard: IEC 680068-2-1, Test Ad
	Special conditions: <ul style="list-style-type: none"> • Temperature: -40°C • Temperature variation: 1°C/min
	Operating conditions: Powered ON with a power cycle of 1 minute ON and 2 minutes OFF
	Duration: 3 days
Resistance to Heat Test RH 	Standard: IEC 680068-2-2, Test Bb
	Special conditions: <ul style="list-style-type: none"> • Temperature: +85°C • Temperature variation: 1°C/min
	Operating conditions: Powered ON with a power cycle of 15 minutes ON and 15 minutes OFF
	Duration: 50 days

6.2.3. Corrosive Resistance Stress Tests

The following tests the AirPrime HL7518 module’s resistance to corrosive atmosphere.

Table 29. Corrosive Resistance Stress Tests

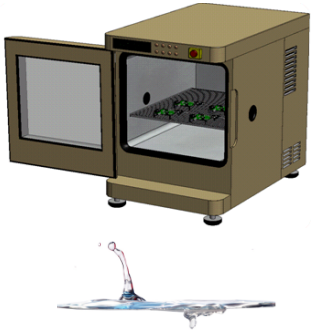
Designation	Condition
Humidity Test HUT 	Standard: IEC 60068-2-3, Test Ca
	Special conditions: <ul style="list-style-type: none"> • Temperature: +65°C • RH: 95% • Temperature variation: 3 ± 0.6°C/min
	Operating conditions: Powered on, DUT is powered up for 15 minutes and OFF for 15 minutes
	Duration: 10 days

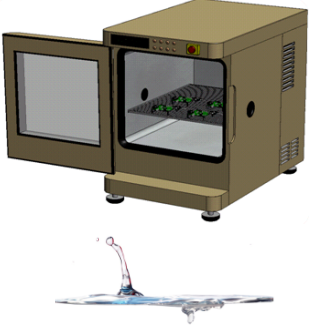
Designation	Condition
Component Solder Wettability CSW 	Standard: JESD22 – B102, Method 1/Condition C, Solderability Test Method
	Special conditions: Test method: Dip and Look Test with Steam preconditioning 8 h ± 15min. dip for 5 +0/-0.5 seconds
	Operating conditions: Un-powered
	Duration: 1 day
Moist Heat Cyclic Test MHCT 	Standard: IEC 60068-2-30, Test Db
	Special conditions: <ul style="list-style-type: none"> • Upper temperature: +40 ± 2°C • Lower temperature: +25 ± 5°C • RH: <ul style="list-style-type: none"> ▪ Upper temperature: 93% ▪ Lower temperature: 95% • Number of cycles: 21 (1 cycle/24 hours) • Temperature Variation: 3 ± 0.6°C/min
	Operating conditions: Powered ON for 15 minutes during each 3 hours ramp up and 3 hours ramp down (in middle) for every cycle
	Duration: 21 days

6.2.4. Thermal Resistance Cycle Stress Tests

The following tests the AirPrime HL7518 module’s resistance to extreme temperature cycling.

Table 30. Thermal Resistance Cycle Stress Tests

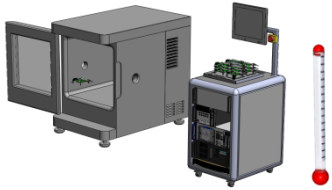
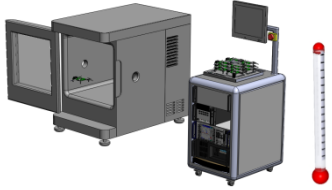
Designation	Condition
Thermal Shock Test TSKT 	Standard: IEC 60068-2-14, Test Na
	Special conditions: <ul style="list-style-type: none"> • Temperature: -30°C to +80°C • Temperature Variation: less than 30s • Number of cycles: 600 • Dwell Time: 10 minutes
	Operating conditions: Un-powered
	Duration: 9 days
Temperature Change TCH 	Standard: IEC 60068-2-14, Test Nb
	Special conditions: <ul style="list-style-type: none"> • Temperature: -40°C to +90°C • Temperature Variation: 3 ± 0.6°C/min • Number of cycles: 400 • Dwell Time: 10 minutes
	Operating conditions: Un-powered
	Duration: 29 days

6.2.5. Mechanical Resistance Stress Tests

The following tests the AirPrime HL7518 module’s resistance to vibrations and mechanical shocks.

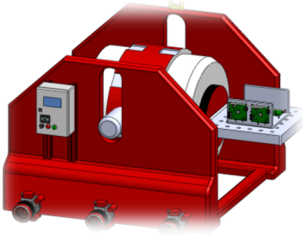
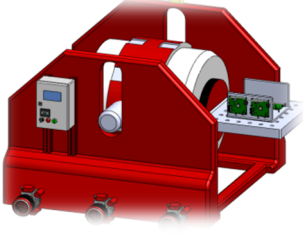
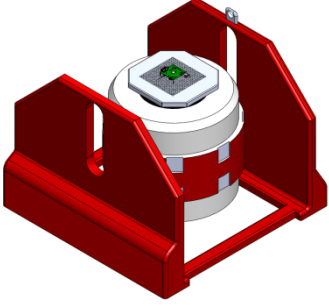
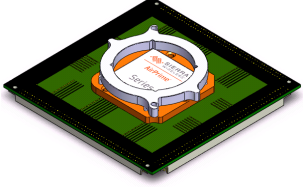

Table 31. Mechanical Resistance Stress Tests

Designation	Condition
Sinusoidal Vibration Test SVT 	Standard: IEC 60068-2-6, Test Fc
	Special conditions: <ul style="list-style-type: none"> • Frequency range: 16 Hz to 1000 Hz • Displacement: 0.35mm (peak-peak) • Acceleration: <ul style="list-style-type: none"> ▪ 5G from 16 to 62 Hz ▪ 3G from 62 to 200 Hz ▪ 1G from 200 to 1000 Hz • Sweep rate: 1 octave / cycle • Number of Sweep: 20 sweeps/axis • Sweep direction: ±X, ±Y, ±Z
	Operating conditions: Un-powered
	Duration: 2 days
Random Vibration Test RVT 	Standard: IEC 60068-2-64, Test Fh
	Special conditions: <ul style="list-style-type: none"> • Frequency range: 10 Hz – 2000 Hz • Power Spectral Density in [(m/s²)²/Hz] <ul style="list-style-type: none"> ▪ 0.1 g²/Hz at 10Hz ▪ 0.01 g²/Hz at 250Hz ▪ 0.005 g²/Hz at 1000Hz ▪ 0.005 g²/Hz at 2000Hz • Peak factor: 3 • Duration per Axis: 1 hr / axis
	Operating conditions: Un-powered
	Duration: 1 day
Mechanical Shock Test MST 	Standard: IEC 60068-2-27, Test Ea
	Special conditions: <ul style="list-style-type: none"> • Shock Test 1: <ul style="list-style-type: none"> ▪ Wave form: Half sine ▪ Peak acceleration: 30g ▪ Duration: 11ms ▪ Number of shocks: 8 ▪ Direction: ±X, ±Y, ±Z • Shock Test 2: <ul style="list-style-type: none"> ▪ Wave form: Half sine ▪ Peak acceleration: 100g ▪ Duration: 6ms ▪ Number of shocks: 3 ▪ Direction: ±X, ±Y, ±Z
	Operating conditions: Un-powered
	Duration: 72 hours

6.2.6. Handling Resistance Stress Tests

The following tests the AirPrime HL7518 module’s resistance to handling malfunctions and damage.

Table 32. Handling Resistance Stress Tests

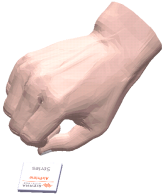
Designation	Condition
ESDC Test 	Standard: JESD22-A114, JESD22-A115, JESD22-C101
	Special conditions: <ul style="list-style-type: none"> • HBM (Human Body Model): 1KV (Class 1C) • MM (Machine Model): 200V • CDM (Charged Device Model): 250V (Class II)
	Operating conditions: Powered
	Duration: 3 days
ESD Test 	Standard: IEC 61000-4-2
	Special conditions: <ul style="list-style-type: none"> • Contact Voltage: ±2kV, ±4kV, ±6kV • Air Voltage: ±2kV, ±4kV, ±8kV
	Operating conditions: Powered
	Duration: 3 days
Free Fall Test FFT 1 	Standard: IEC 60068-2-32, Test Ed
	Special conditions: <ul style="list-style-type: none"> • Number of drops: 2 drops per unit • Height: 1m
	Operating conditions: Un-powered
	Duration: 6 hours

7. FCC Legal Information

The HL7518 module has been granted modular approval for mobile applications. Integrators may use the HL7518 module in their final products without additional FCC certification if they meet the following conditions. Otherwise, additional FCC approvals must be obtained.

1. At least 20 cm separation distance between the antenna and the user's body must be maintained at all times.
2. To comply with FCC regulations limiting both maximum RF output power and human exposure to RF radiation, the maximum antenna gain including cable loss in a mobile-only exposure condition must not exceed:
 - 6 dBi in LTE Band 4
 - 9 dBi in LTE Band 13
3. The HL7518 module must not transmit simultaneously with other collocated radio transmitters within a host device.
4. The RF signal must be routed on the application board using tracks with a 50Ω characteristic impedance. Basically, the characteristic impedance depends on the dielectric, the track width and the ground plane spacing. In order to respect this constraint, Sierra Wireless recommends using MicroStrip or StripLine structure and computing the Tracks width with a simulation tool (like AppCad shown in the figure below and that is available free of charge at <http://www.agilent.com>).

AppCAD - [Microstrip]

File Calculate Select Parameters Options Help

Main Menu [F8]

Microstrip

Calculate Z0 [F4]

W 700

H 400

T 35

L 10000

Dielectric: $\epsilon_r = 4,6$

FR-4

Frequency: 1800 MHz

Length Units: μm

Z0 = 50,22 Ω

Elect Length = 0,110 λ

Elect Length = 39,6 degrees

1.0 Wavelength = 90806,456 μm

Vp = 0,545 fraction of c

$\epsilon_{\text{eff}} = 3,364$

W/H = 1,750

Normal Click for Web: APPLICATION NOTES - MODELS - DESIGN TIPS - DATA SHEETS - S-PARAMETERS

If a multi-layered PCB is used, the RF path on the board must not cross any signal (digital, analog or supply).

If necessary, use Stripline structure and route the digital line(s) "outside" the RF structure. An example of proper routing is shown in the figure below.



Stripline and Coplanar design requires having a correct ground plane at both sides. Consequently, it is necessary to add some vias along the RF path. It is recommended to use Stripline design if the RF path is fairly long (more than 3cm), since MicroStrip design is not shielded. Consequently, the RF signal (when transmitting) may interfere with neighbouring electronics (AF amplifier, etc.). In the same way, the neighbouring electronics (micro-controllers, etc.) may degrade the reception performances. The GSM/GPRS connector is intended to be directly connected to a 50Ω antenna and no matching is needed.

5. A label must be affixed to the outside of the end product into which the HL7518 module is incorporated, with a statement similar to the following:

This device contains FCC ID: **N7NHL7518**

6. A user manual with the end product must clearly indicate the operating requirements and conditions that must be observed to ensure compliance with current FCC RF exposure guidelines.

The end product with an embedded HL7518 module may also need to pass the FCC Part 15 unintentional emission testing requirements and be properly authorized per FCC Part 15.

Note: If this module is intended for use in a portable device, you are responsible for separate approval to satisfy the SAR requirements of FCC Part 2.1093.



8. Ordering Information

Table 33. Ordering Information

Model Name	Description	Part Number
HL7518	HL7518 embedded module	Contact Sierra Wireless for the latest SKU
DEV-KIT	HL Series Development Kit	6000620

9. Terms and Abbreviations

Abbreviation	Definition
ADC	Analog to Digital Converter
AGC	Automatic Gain Control
AT	Attention (prefix for modem commands)
CDMA	Code Division Multiple Access
CF3	Common Flexible Form Factor
CLK	Clock
CODEC	Coder Decoder
CPU	Central Processing Unit
DAC	Digital to Analog Converter
DTR	Data Terminal Ready
EGNOS	European Geostationary Navigation Overlay Service
EMC	Electromagnetic Compatibility
EMI	Electromagnetic Interference
EN	Enable
ESD	Electrostatic Discharges
ETSI	European Telecommunications Standards Institute
FDMA	Frequency-division multiple access
GAGAN	GPS aided geo augmented navigation
GLONASS	Global Navigation Satellite System
GND	Ground
GNSS	Global Navigation Satellite System
GPIO	General Purpose Input Output
GPRS	General Packet Radio Service
GSM	Global System for Mobile communications
Hi Z	High impedance (Z)
IC	Integrated Circuit
IMEI	International Mobile Equipment Identification
I/O	Input / Output
LED	Light Emitting Diode
LNA	Low Noise Amplifier
MAX	Maximum
MIN	Minimum
MSAS	Multi-functional Satellite Augmentation System
N/A	Not Applicable
PA	Power Amplifier
PC	Personal Computer
PCB	Printed Circuit Board
PCL	Power Control Level
PLL	Phase Lock Loop
PWM	Pulse Width Modulation
QZSS	Quasi-Zenith Satellite System

Abbreviation	Definition
RF	Radio Frequency
RFI	Radio Frequency Interference
RMS	Root Mean Square
RST	Reset
RTC	Real Time Clock
RX	Receive
SCL	Serial Clock
SDA	Serial Data
SIM	Subscriber Identification Module
SMD	Surface Mounted Device/Design
SPI	Serial Peripheral Interface
SW	Software
PSRAM	Pseudo Static RAM
TBC	To Be Confirmed
TBD	To Be Defined
TP	Test Point
TX	Transmit
TYP	Typical
UART	Universal Asynchronous Receiver-Transmitter
UICC	Universal Integrated Circuit Card
USB	Universal Serial Bus
UIM	User Identity Module
VBATT	Main Supply Voltage from Battery or DC adapter
VSWR	Voltage Standing Wave Ratio
WAAS	Wide Area Augmentation System